

Dismantling Procedure			
<b>Recycling ID</b>			
Name:	Recycling Product Information for AudioCodes MP-11X Series		
Document p/n:	A91001-001	REV. A01	ACL p/n : N/A
Directive 2002/96/EC			

Release and Revision Record			
New Procedure File <input checked="" type="checkbox"/>			
Updated Procedure File <input type="checkbox"/>			
Edited: Aviv Shloush		Approved: Sason Atia	
Rev	Description	Date Approved	Approved By
A01	Initial Release	20/05/2012	

Document Type:	Dismantling Procedure		
Document Name:	Recycling Product Information Audiocodes MP11X		
Document Number:	A91001-001	Revision:	A01

## **General**

Directive 2002/96/EC of the European Parliament and of the Council on Waste Electrical and Electronic Equipment (WEEE) requires the manufacturer to supply To Whom It May Concern reuse and recycle information about their products.

## **Manufacturer details:**

Company: Audiocodes  
Address: 1 Hayarden Street, Airport City, LOD 70100, ISRAEL.

## **Equipment Information:**

Product name: MP11X

Product general drawing:

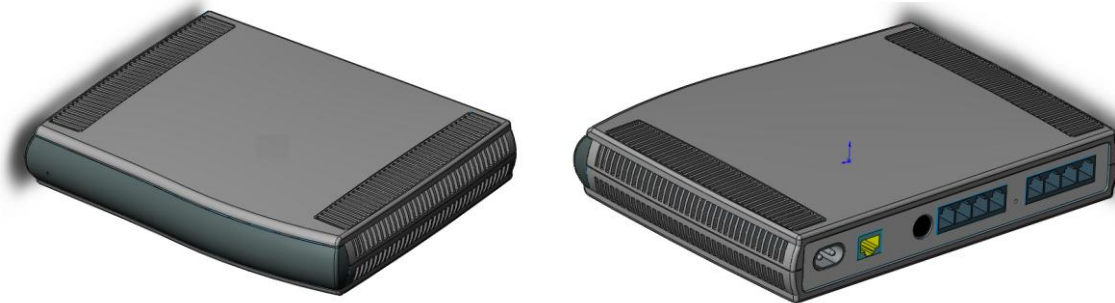

Equipment net weight: 0.8KG

Equipment dimensions: 220\*180\*45\*mm

## **Equipment Information:**

- Safety-Marks and other Marks on the Product Label: CE
- Restricted Substances: No

Document Type:	Dismantling Procedure		
Document Name:	Recycling Product Information Audiocodes MP11X		
Document Number:	A91001-001	Revision:	A01

- Batteries (Yes/No; Type; Weight): No

Disposal of used Electrical & Electronic Equipment:

- Applicable in the European Union and other European countries with separate collection system.
- The symbol below, when posted on the product or in the product's manual and/or on its packaging box indicates that this product shall not be treated as household waste.
- For more detailed information about take-back and recycling of this product, please contact your local service organization. By ensuring this product is disposed-off correctly, you will help preventing potential negative consequences for the environment and human health, which could otherwise be caused by inappropriate waste handling of this product. The recycling of materials will also help to conserve natural resources.
- If equipment contains easy removable batteries or accumulators, they should be disposed separately according to Directive 2006/66/EC and your State requirements.



**Recycling Information:**

- The Product contains material / components under or with:

		NO	If YES specify
1	Pressure	/	
2	Liquids (please specify below)	/	
3	Gasses (please specify below)	/	
4	"Hidden" mechanical springs or other harmful equivalents	/	
5	Risk for explosion during treatment	/	
6	Risk as fire hazard during treatment	/	
7	Other risks (please specify below)	/	

Document Type:	Dismantling Procedure		
Document Name:	Recycling Product Information Audiocodes MP11X		
Document Number:	A91001-001	Revision:	A01

- To the best of our knowledge, the product contains the following materials / components to be removed:

		NO	If YES specify (for location, review the scheme on page 5)
9	Polychlorinated biphenyls (PCB) containing capacitors	/	
10	Mercury containing components, such as switches or backlighting lamps	/	
11	Batteries	/	
12	Printed circuit boards with surfaces greater than 10 square centimeters		
13	Toner cartridges, liquid and pasty, as well as color toner	/	
14	Plastic containing brominated flame retardants	/	
15	Asbestos waste and components which contain asbestos	/	
16	Cathode ray tubes	/	
17	Chlorofluorocarbons (CFC), hydro chlorofluorocarbons (HCFC) or hydro fluorocarbons (HFC), hydrocarbons (HC)	/	
18	Gas discharge lamps	/	
19	Liquid crystal displays (together with their casing where appropriate) of a surface greater than 100 square centimeters and all those back-lighted with gas discharge lamps	/	
20	External electric cables	/	
21	Components containing refractory ceramic fibers as described in Commission Directive 97/69/EC of 5 December 1997 adapting to technical progress Council Directive 67/548/EEC relating to the classification, packaging and labeling of dangerous substances	/	
22	Components containing radioactive substances with the exception of components that are below the exemption thresholds set in Article 3 of and Annex I to Council Directive 96/29/Erratum of 13 May 1996	/	
23	Electrolyte capacitors containing substances of concern (height > 25 mm, diameter > 25 mm or proportionately similar volume)	/	

- Others:

		NO	If YES specify (Review the location on the scheme on page 5)
26	Beryllium oxide, Beryllium and its compounds	/	
27	Cadmium and its compounds	/	
28	Plastic with other flame retardants (please specify):	/	

- Remarks:

topic No.	Specification

Document Type:	Dismantling Procedure		
Document Name:	Recycling Product Information Audiocodes MP11X		
Document Number:	A91001-001	Revision:	A01

**Materials and components which have to be removed and treated separately**

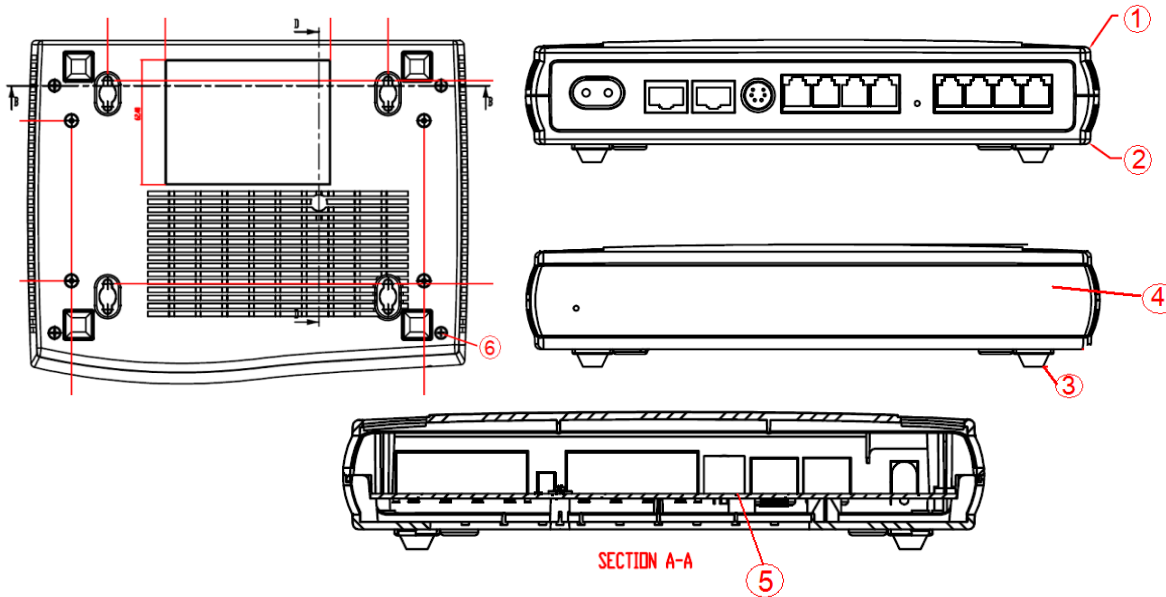

	Components	Material	Details
1	4 screws on bottom of product	Stainless steel	Unscrew & take off, balloon 6
2	Cover	Plastic PC/ABS	Take off, balloon 1
3	Main board	PCBA	Take off
4	Front panel	Polycarbonate	Take off, balloon 4
5	Rear panel	PCB / Metal	Take off, balloon 2
6	4 Bumper legs on bottom of product	polyurethane	Take off, balloon 3