

## Quick Guide

### 1. Before Installing

Congratulations on purchasing your **AudioCodes C456HD for Microsoft Teams IP Phone!**

Before installing your phone, make sure the following items are included in the shipped box / boxes:

- ✓ C456HD IP Phone
- ✓ Expansion Module (optional, purchased separately)
- ✓ AC power adapter (optional)
- ✓ Cat 5e Ethernet cable
- ✓ Handset
- ✓ Handset cord
- ✓ Desktop stand
- ✓ Wall mount

### 2. Physical Description





**Note:** The Expansion Module option is purchased separately. For instructions on how to connect it to the phone, see the *C456HD Expansion Module Installation Guide*.

### 3. Cabling the Phone



**Warning:** Prior to connecting power, refer to the Compliance and Regulatory Information document at <https://www.audiocodes.com/library/technical-documents>.

#### To cable the phone:

1. Connect the short, straight end of the handset cord to the handset, and the longer straight end of the cord, to the handset jack on the phone.
2. (Optional) Connect a headset to the USB-3 port.
3. Connect the RJ-45 LAN port to your LAN network (LAN port or LAN switch/router) with a CAT 5 / 5e Ethernet cable.
4. Connect the RJ-45 PC port to a computer with a CAT 5 / 5e straight-through Ethernet cable.
5. Power the phone using **one** of the following methods:
  - **PoE:** If the connected LAN port provides Power over Ethernet (PoE), the phone is powered through the LAN cable. No external power adapter is required.
  - **AC power adapter (optional):** Connect an AC power adapter provided by AudioCodes (sold separately) to the phone's DC 12V power socket, and then plug it into an electrical outlet.



- **Do not use both PoE and an AC power adapter simultaneously.**
- Wi-Fi is supported only when the phone is powered by an AC power adapter.

When the phone powers up, all the LEDs momentarily light up.

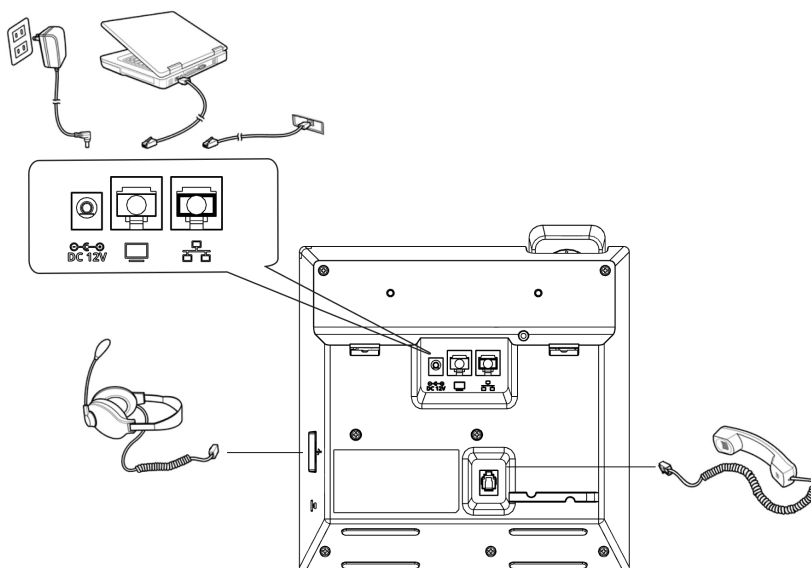

## 4. Mounting Phone on Desktop

Your phone is shipped with a desk stand.

### To desk mount phone:

1. Align the two hooks of the desk stand (supplied) with the corresponding slots on the phone base.
2. Gently push the stand down until it snaps securely into place.
3. Secure the stand to the phone by fastening the two screws (supplied).

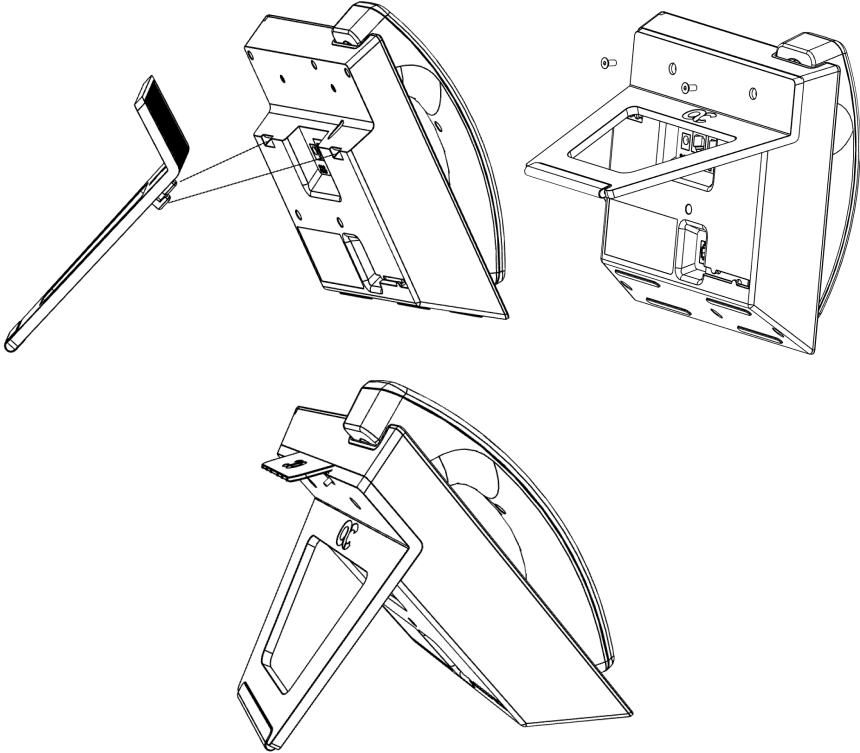

## 5. Mounting Phone on Wall

Use AudioCodes wall-mounting bracket kit (separate orderable item) to mount the phone on a wall. It allows you to mount the phone anywhere on a wall or to hang it on your Ethernet wall plate.

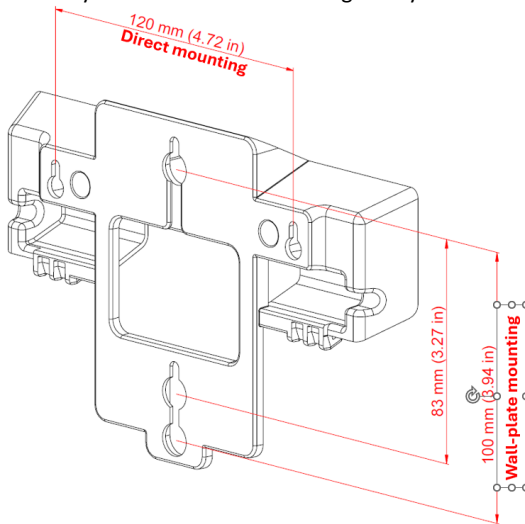

### To wall-mount the phone:

1. Align the two clips of the wall-mounting bracket (separate orderable item) with the corresponding slots on the bottom of the phone.
2. Gently push the bracket down until it snaps securely into place.
3. Secure the bracket to the phone by inserting the two screws.

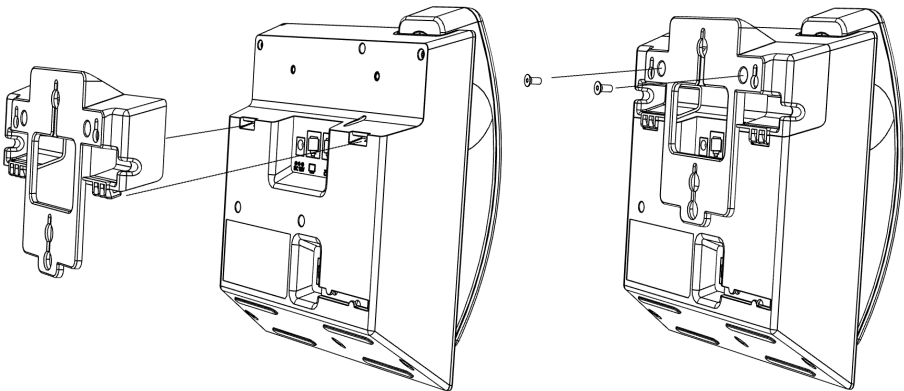

4. Mount anywhere on a wall
  - a. Mark the locations of the screw holes on the wall.

- b. Drill a hole in the wall for each location.
  - c. Insert wall anchors (not supplied) into the holes and insert screws (not supplied) into them.
  - d. Leave a gap (approx. 5 mm) between screw head and wall for hanging the mounting bracket.
  - e. Hang the bracket (attached to phone) on the screw heads and tighten the screws if necessary.
5. Hang on an Ethernet wall plate
- a. On the Ethernet wall plate, locate its two mounting standoffs used to wall-mount an IP phone:

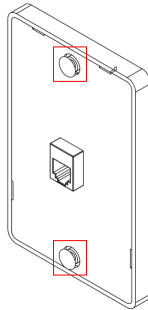

- b. Align the bracket's holes (attached to the phone) over the Ethernet wall plate's mounting standoffs shown in the preceding figure.



**Note:** The holes in the bracket (attached to the phone) comply with multiple mounting standoffs on Ethernet wall plates available in the market.

- c. Press the phone to hang it on the standoffs.

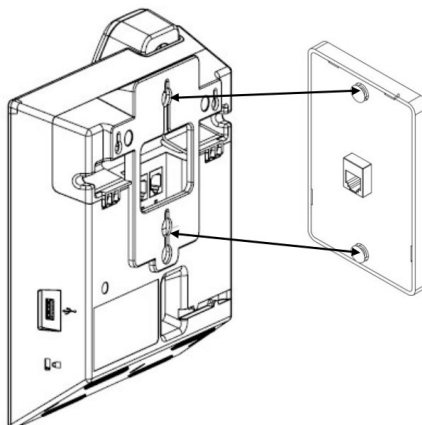

## 6. Getting Started

Getting started with your phone consists of completing the MDEP wizard and signing in.

### To run the MDEP wizard:

1. Connect the device to the power supply, and optionally to the network.



2. Select the requested language.



3. Set the region and network (only relevant if the device is not connected to the network).



4. The Microsoft Privacy screen is displayed; click **LEARN MORE**.

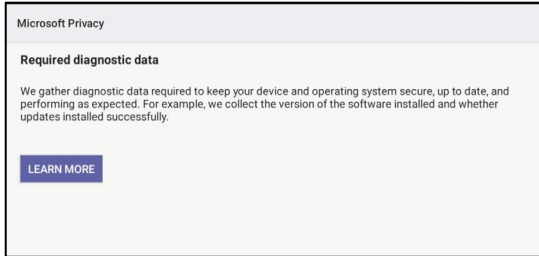

5. Accept the Microsoft Privacy Statement.

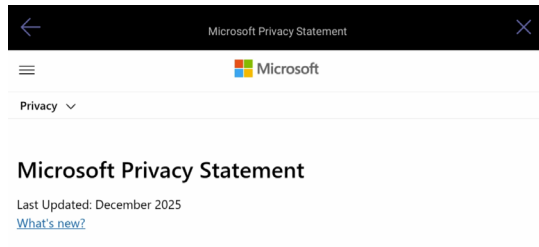

6. Enter and confirm a new password.

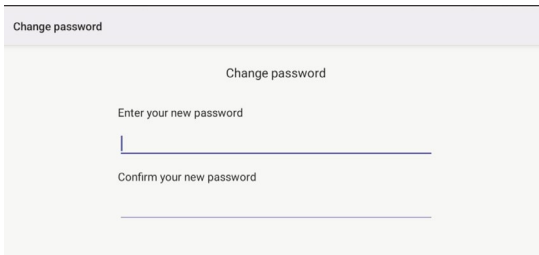

The device starts up and is ready for sign-in.

 **To sign in to your account:**

1. Connect the device to the network.

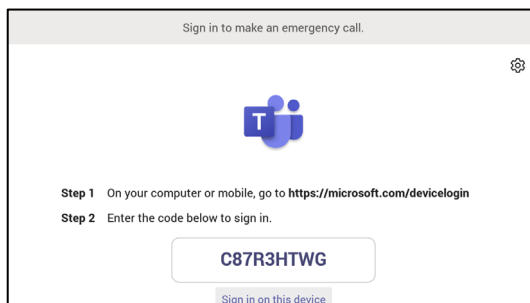

2. Point your browser to <https://microsoft.com/devicelogin> as instructed.

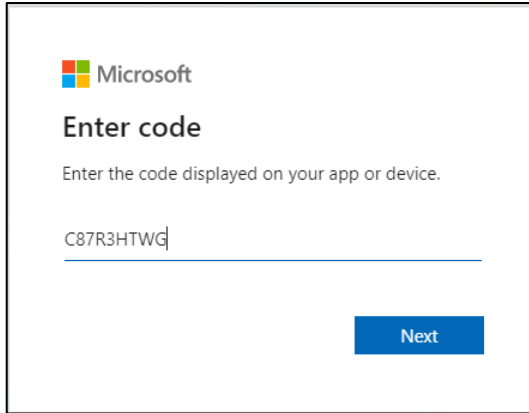

3. In the browser, enter the code as shown and click **Next**.

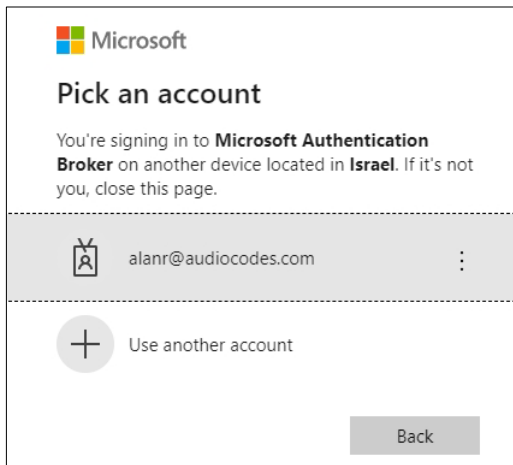

4. Click the account, close the 'Microsoft Authentication Broker' window, and then **Continue**.

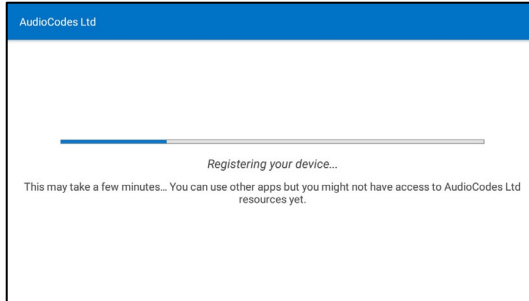

5. View the home screen; you've successfully signed in.

See also [here](#) a brief introductory video clip demonstrating signing in to AudioCodes Teams phones.

## 7. Changing your Presence Status

### To change your presence status:

- Swipe right, touch the current presence status, and then select the status you require.

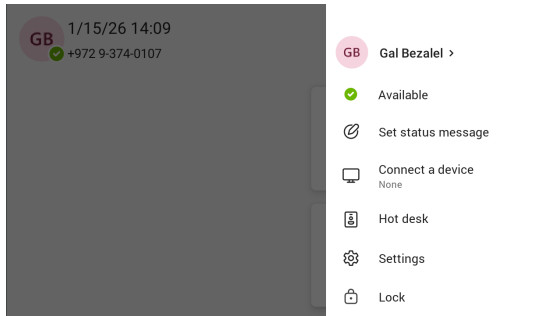

## 8. Basic Phone Operations

For basic phone operations, refer to Microsoft documentation and the *User's and Administrator's Manual*.

## 9. Connecting to a Router via Wi-Fi

The phone can connect to an Access Point via Wi-Fi. The Wi-Fi interface can be used to make VoIP calls over Wi-Fi when the phone is installed in an environment free of LAN/cables.

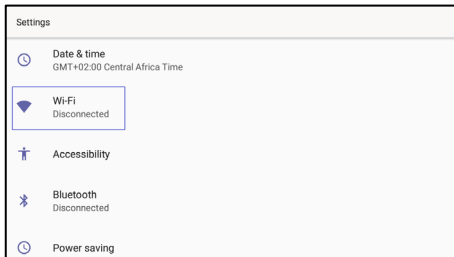

✓ You can connect to Wi-Fi by navigating to the 'Settings' menu and then selecting the **Wi-Fi** option.

## 10. Enabling or Disabling Wi-Fi

### To enable Wi-Fi:

1. Turn Wi-Fi on by moving the switch in the upper right corner (Wi-Fi is disabled by default).

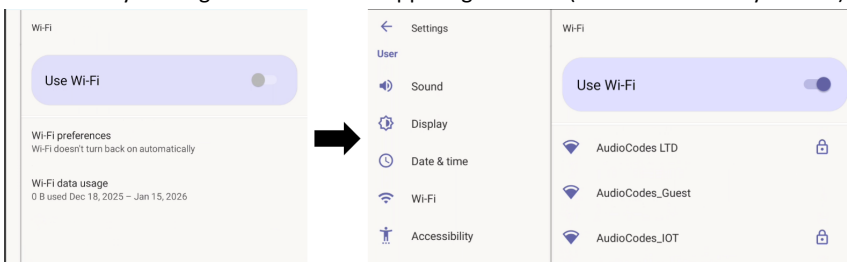

2. After enabling Wi-Fi, "Searching for Wi-Fi networks..." is displayed. The phone then displays the available Wi-Fi Access Points. Select the desired Wi-Fi Access Point (network).

3. Enter the Wi-Fi password if needed, and then tap **Connect**.

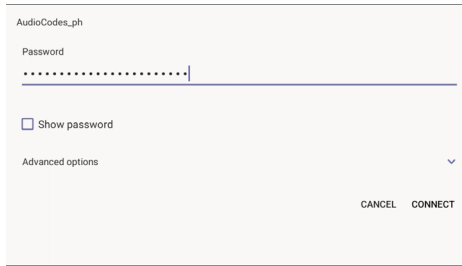

4. When connected to the Access Point, the active network is highlighted:

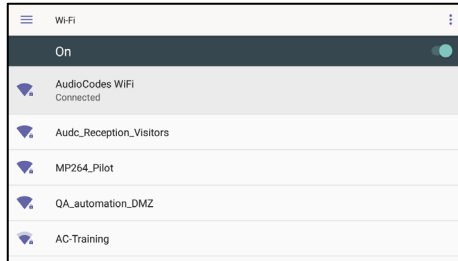

International Headquarters  
Naimi Park  
6 Ofra Haza  
Or Yehuda, Israel  
Tel: +972-3-976-4000  
Fax: +972-3-976-4040

AudioCodes Inc.  
80 Kingsbridge Rd  
Piscataway, NJ 08854, USA  
Tel: +1-732-469-0880  
Fax: +1-732-469-2298

**Contact us:** <https://www.audiocodes.com/corporate/offices-worldwide>  
**Website:** <https://www.audiocodes.com/>

©2026 AudioCodes Ltd. All rights reserved. AudioCodes, AC, HD VoIP, HD VoIP Sounds Better, IPmedia, Mediant, MediaPack, What's Inside Matters, OSN, SmartTAP, User Management Pack, VMAS, VoIPerfect, VoIPerfectHD, Your Gateway To VoIP, 3GX, AudioCodes One Voice, AudioCodes Meeting Insights and AudioCodes Room Experience are trademarks or registered trademarks of AudioCodes Limited. All other products or trademarks are property of their respective owners. Product specifications are subject to change without notice.



**FCC Warning:** Prior to operating this device, refer to the device's [Regulatory Information and FCC warnings](#).

## Notice Information

Information contained in this document is believed to be accurate and reliable at the time of printing. However, due to ongoing product improvements and revisions, AudioCodes cannot guarantee accuracy of printed material after the Date Published nor can it accept responsibility for errors or omissions. Updates to this document can be downloaded from <https://www.audiocodes.com/library/technical-documents>.

This document is subject to change without notice.

Date Published: Jun-24-2026

Document #: LTRT-13446

