

IP Phone – Generic SIP

For C450HD IP Phone

Version 3.5.4

Table of Contents

Notice	v
Security Vulnerabilities	v
WEEE EU Directive	v
Customer Support	v
Stay in the Loop with AudioCodes	v
Abbreviations and Terminology.....	v
Related Documentation.....	vi
Document Revision Record.....	vi
Documentation Feedback.....	vi
1 Introduction	1
1.1 C450HD IP Phone Overview.....	1
1.2 Highlights.....	1
2 Setting up the Phone	3
2.1 Unpacking.....	3
2.2 Device Description.....	4
2.2.1 Front View.....	4
2.2.2 Rear View.....	6
2.3 Cabling.....	7
2.4 Mounting the Phone.....	8
2.4.1 Desktop Mounting.....	8
2.4.2 Mounting the Expansion Unit on a Desktop.....	8
2.4.2.1 Routing the Handset Cable.....	8
2.4.3 Wall Mounting	8
3 Getting Started	10
3.1 Getting Acquainted with the Phone's Screen	10
3.2 Softkeys	11
3.3 Navigating the Phone Menu	12
3.4 Inputting Data Using the Virtual Keyboard	13
3.4.1 Changing Case	15
3.4.2 Switching Between Input Modes	15
3.4.2.1 Selecting an Alphanumerical Mode	15
3.5 Inputting Data Using Multi-Tap	16
3.5.1 Switching between Letters and Numbers	17
3.5.2 Switching to Symbols	18
4 Performing Basic Phone Operations	19
4.1 Using Audio Devices	19
4.2 Managing Calls	20

4.2.1	Dialing	21
4.2.2	Redialing	22
4.2.3	Dialing a Missed Call	22
4.3	Answering Calls	23
4.4	Rejecting Incoming Calls	24
4.5	Silencing Incoming Calls	24
4.6	Making a New Call Even Though a Call is Coming in	24
4.7	Ending an Established Call	24
4.8	Viewing the Call Log	25
4.9	Using Multiple Lines	27
4.9.1	Choosing a Line	27
4.9.2	Making a Call on a Line	27
4.9.3	Making Two Calls on a Line	27
4.9.4	Making Multiple Line Calls	28
4.9.5	Toggling Between Multiple-Line Calls	28
4.9.6	Toggling Between Calls on the Same Line	29
4.9.7	Ending Calls	29
4.10	Paging a Group	29
4.10.1	Receiving an Incoming Paging Call	30
4.10.1.1	If Paged when in a Regular Call and Barge-in is Disabled	30
4.10.1.2	If Paged when in a Regular Call and Barge-in is Enabled	31
4.11	Using the Phone's Automatic Lock Feature	31
4.11.1	Unlocking a Locked Phone	33
4.11.2	Manually Changing the Lock Code	34
5	Virtual Sidecar for Shared Lines	35
5.1	Overview	35
5.2	Navigating the Virtual Sidecar	36
5.3	Managing Calls	37
5.3.1	Incoming and Outgoing Calls	37
5.3.2	Managing Multiple Calls	38
5.3.3	Shared Line Management	39
6	Configuring and Customizing Your Phone	40
6.1	Displayed Messages	40
6.2	Changing the Screen Language	40
6.3	Configuring Lines and Wi-Fi	40
6.4	Selecting Ring Tone	43
6.5	Enabling Call Waiting	44
6.6	Managing Simultaneous Incoming Calls	45
6.7	Configuring Call Forwarding	46
6.8	Configuring Time and Date Settings	49

6.8.1	Making Sure the NTP Server is Enabled	49
6.9	Configuring Screen Brightness	51
6.10	Configuring a Default Audio Device	52
6.11	Adjusting Volume	53
6.11.1	Adjusting Ring Volume	53
6.11.2	Volume Mixer Control of multiple streams	53
6.11.3	Adjusting Tones Volume	54
6.11.4	Adjusting Handset Volume	54
6.11.5	Adjusting Speaker Volume	55
6.11.6	Adjusting Headset Volume	55
6.12	Managing your Personal Directory	56
6.12.1	Adding a Contact to the Personal Directory	56
6.12.2	Editing Contact Information	57
6.12.3	Deleting a Contact from the Personal Directory	58
6.12.4	Searching for a Contact in the Personal Directory	59
6.13	Programmable Softkeys (PSKs)	60
6.13.1	Customized UI Experience	61
6.14	Configuring a Function/Programmable Key as a Speed Dial	62
6.14.1	Configuring a Programmable Key for Speed Dialing via Calling Line of Choice	63
6.14.2	Configuring Pause Dialing for a Speed Dial to an Ext. behind an IVR	63
6.14.3	Configuring a Speed Dial Key through the Personal Directory	63
6.14.4	Configuring a Speed Dial Key in the Sidecar Fields	64
6.14.5	Editing a Speed Dial	64
6.14.6	Deleting a Speed Dial	65
6.15	Configuring a Function/Programmable Key for Direct Voice Dialing	65
6.16	Configuring a Function/Programmable Key for Paging	67
6.17	Deleting a Function/Programmable Key	68
7	Performing Advanced Operations	69
7.1	Answering Waiting Calls	69
7.2	Placing Calls On Hold	70
7.3	Calling a Contact Listed in the Directory	70
7.4	Accessing Office 365 Exchange Services in Generic SIP Mode	71
7.5	Using Office365	72
7.6	Handling Multiple Incoming Calls	73
7.7	Using a Speed Dial to Call a Contact	74
7.8	Accessing Speed Dials when in a Call	75
7.9	Transferring Calls	76
7.9.1	Performing a Blind Transfer	76
7.9.2	Transferring a Call to a Remote Party on Hold	78
7.9.3	Merging Calls	79

7.9.4	Leaving a 3-Way Conference You Set up without Disconnecting the Others	79
7.10	Activating Do Not Disturb	81
7.11	Retrieving Voice Mail Messages	82
7.12	Parking a Call	83
7.13	Configuring Group Call Pickup (GCP)	84
7.14	BLF Call Pickup	84
7.15	Managing a Conference	84
7.16	Muting the Microphone	85
7.17	Screens Switcher	86
7.18	Configuring Bluetooth on the Phone	87
8	Troubleshooting and Support	89
8.1	Monitor the Status of Software Modules	89
8.2	Manually Reboot IP Phone	90

Notice

Information contained in this document is believed to be accurate and reliable at the time of printing. However, due to ongoing product improvements and revisions, AudioCodes cannot guarantee accuracy of printed material after the Date Published nor can it accept responsibility for errors or omissions. Updates to this document can be downloaded from <https://www.audiocodes.com/library/technical-documents>.

This document is subject to change without notice.

Date Published: April-24-2025

Security Vulnerabilities

All security vulnerabilities should be reported to vulnerability@audiocodes.com.

WEEE EU Directive

Pursuant to the WEEE EU Directive, electronic and electrical waste must not be disposed of with unsorted waste. Please contact your local recycling authority for disposal of this product.

Customer Support

Customer technical support and services are provided by AudioCodes or by an authorized AudioCodes Service Partner. For more information on how to buy technical support for AudioCodes products and for contact information, please visit our website at <https://www.audiocodes.com/services-support/maintenance-and-support>.

Stay in the Loop with AudioCodes



Abbreviations and Terminology

Each abbreviation, unless widely used, is spelled out in full when first used.

Related Documentation

Document Name
C450HD IP Phone Quick Guide - Generic SIP
400HD Series IP Phones Administrator's Manual
Device Manager Pro Administrator's Manual
One Voice Operations Center IOM Manual
One Voice Operations Center (OVOC) User's Manual
Live Platform Guide for AudioCodes Professional Services
Live Platform Service Providers User's Manual
Live Platform Channel Resellers User's Manual
Live Platform End Customers User's Manual

Document Revision Record

LTRT	Description
13278	This is the initial release of the document.
14854	This document has been updated to be compatible with IP phone 3.5.4.
14857	Added Monitor the Status of Software Modules feature

Documentation Feedback

AudioCodes continually strives to produce high quality documentation. If you have any comments (suggestions or errors) regarding this document, please fill out the Documentation Feedback form on our website at <https://online.audiocodes.com/documentation-feedback>.

1 Introduction

1.1 C450HD IP Phone Overview

The **AudioCodes C450HD IP Phone** is a state-of-the-art communication device tailored for executive business environments powered by AudioCodes' High Definition voice technology, the C450HD ensures exceptional voice clarity for Voice-over-IP (VoIP) calls and seamless integration with Microsoft Teams for unified collaboration.

Designed to meet the needs of high-end business users, the C450HD features:

- **5-Inch Color Touch Screen:** A high-resolution (1280 x 720) capacitive touch display for an intuitive user experience.
- **Enhanced Connectivity Options:** Optional integrated Bluetooth and Wi-Fi (availability varies by region).
- **Rich Call Management Features:** Placing and receiving calls, hold, transfer, and conference calling.
- **Scalable Functionality:** Support for an optional Expansion Module for increased productivity.
- **Manageability:** Compatible with the AudioCodes Device Manager, and AudioCodes Redirect Server for streamlined monitoring, upgrading, and configuration.

As part of AudioCodes' **Managed IP Phones solution**, the C450HD can be integrated as an IT-managed device, enabling comprehensive lifecycle management for end-user desktop equipment.

Please read this **User Manual** carefully to familiarize yourself with the phone's operation and its extensive feature set. For additional information and resources, visit the [Microsoft Teams phones documentation](#).



Expansion Module

The Expansion Module option is purchased separately as a standalone unit. For instructions on how to connect it to the phone, see the *C450HD and C455HD Expansion Module Installation Guide*.

1.2 Highlights

The **AudioCodes C450HD IP Phone** is designed with **advanced features** to enhance user experience and efficiency. Key highlights include:

- **Concurrent Call Handling** – Supports **one line with up to eight concurrent calls**, ensuring seamless communication.
- **High-Resolution Displays:** 5-inch color capacitive 1280 x 720 high-resolution touch (TFT) screen.
- **User-Friendly Interface:** Highly intuitive, touch-oriented user interface enabling up to 8 Function softkeys and extensive unified communications functionality.

- **Multi-Language Support** – Enables **seamless operation** across different languages for diverse business environments.
- Expansion module support.
- **Built-in Conferencing** – Provides **efficient audio-conferencing capabilities** for improved collaboration.
- **High-Definition Call Quality** – Delivers **exceptional voice clarity** with support for multiple voice codecs.
- **Centralized Management** – Fully **integrates with AudioCodes' IP phone management system**, making it an **IT-managed device** for streamlined deployment and maintenance.
- **Headset Support:** Two Gigabit Ethernet (GbE) interfaces supported - two ports for headset support, one USB headset at a time.

C450HD IP Phone with Wi-Fi: Wireless connectivity: Single band 2.4GHz, 802.11b/g/n Wi-Fi support.

Note: Wi-Fi is supported in the USA, Canada, the European Union, Switzerland and Israel, and requires a specific CPN with a 'BW' suffix. The list of supported countries is dynamic. Contact your local AudioCodes representative for more information about regional availability and specific country type approvals of Wi-Fi.

Users can connect the phone to an Access Point via Wi-Fi when the phone is installed in an environment free of LAN/cables. See section 6.3, "[Configuring Lines and Wi-Fi](#)" for more information.

- **Comprehensive Deployment:** Can be integrated with other AudioCodes 400HD IP phones as part of a fully managed IP phone solution, with unique and complete centralized device life-cycle management courtesy of AudioCodes' IP phone management utilities for managing end-user desktop devices.
- **Seamless Deployment** – Easily integrates with other **AudioCodes 400HD IP phones** as part of a **fully managed VoIP solution**, with **comprehensive lifecycle management** via AudioCodes' IP phone management utilities.
- **Advanced Audio Technology** – Powered by **AudioCodes' VoIPerfectHD™ software**, featuring:
 - **Wideband codec support** for crystal-clear HD voice.
 - **Packet loss concealment** for improved call stability.
 - **High-quality wideband acoustic echo cancellation** for enhanced audio clarity.
 - **Low-delay adaptive jitter buffers** to ensure smooth voice transmission.
- **Virtual Sidecar** –
 - Available on the C450HD model, the **Virtual Sidecar** enhances call management efficiency.
 - Features **multiple Programmable Keys** for quick access to frequently used functions.
 - Allows users to **navigate and manage multiple lines, active calls, and shared lines effectively**.

2 Setting up the Phone

2.1 Unpacking

When unpacking, ensure that the following items are present and undamaged:

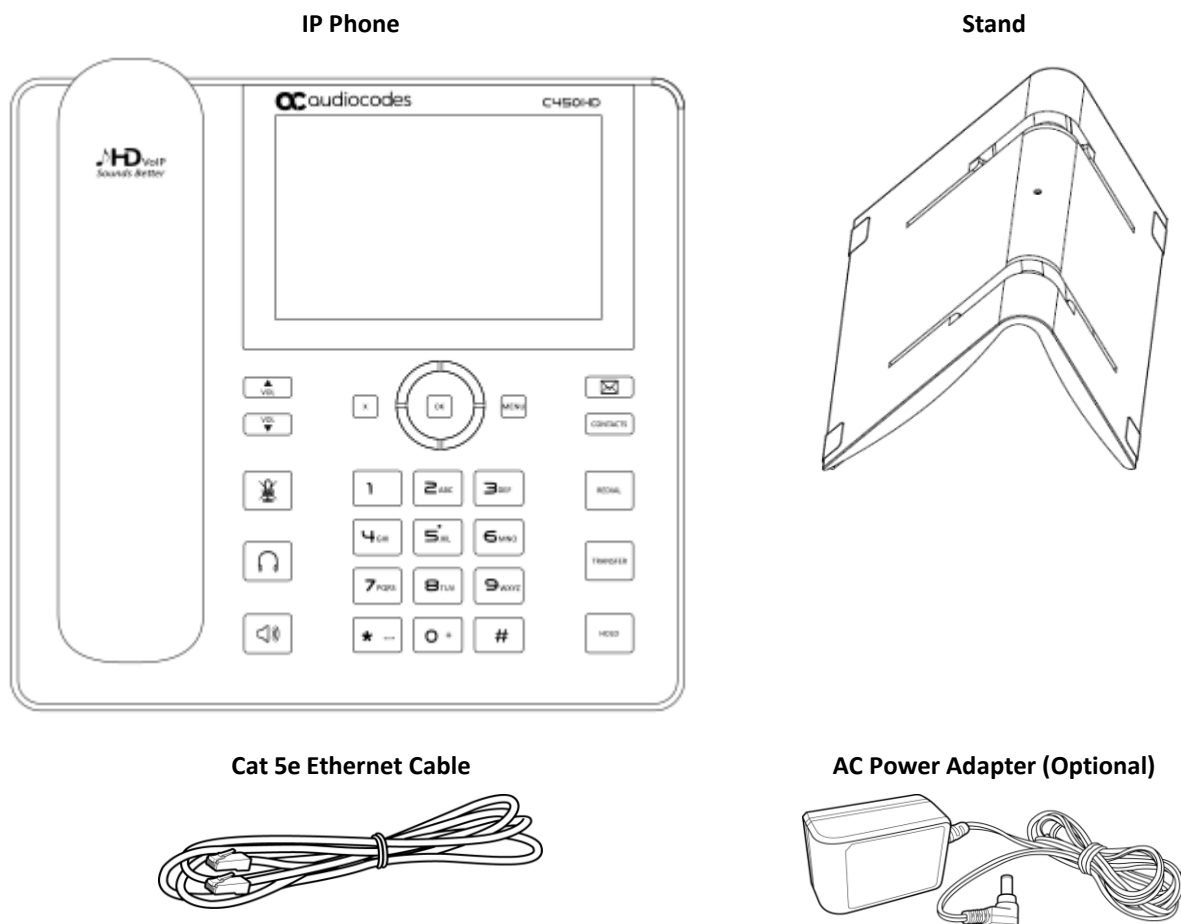

If anything appears to be missing or broken, contact the distributor from whom you purchased the phone for assistance.

2.2 Device Description

Use the graphics below to identify and familiarize yourself with the device's hardware functions.

2.2.1 Front View

The front view of the phone is illustrated in the figure below and explained in detail in the accompanying table.

Figure 1: Front View

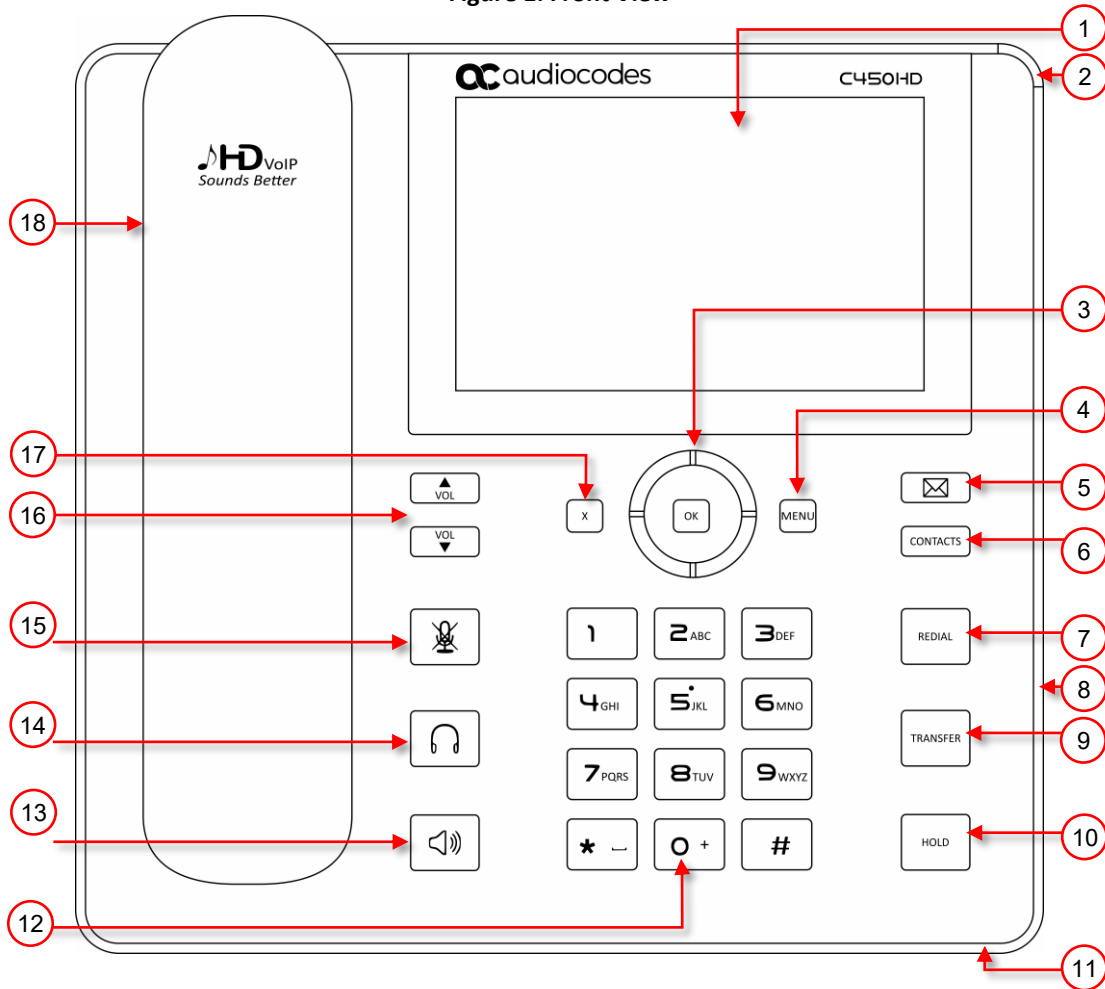

Table 1: Font View Description

Item #	Label/Name	Description
1	TFT touch screen	Thin Film Transistor touch screen, a type of LCD (Liquid Crystal Display) interactive screen which displays calling information and lets you configure phone features by touching the glass.
2	Ring LED	Indicates phone status: <ul style="list-style-type: none"> ■ Green: Idle state ■ Flashing blue: Incoming call (ringing) ■ Red: Answered call
3	Navigation Control / OK	<ul style="list-style-type: none"> ■ Press the button's upper rim to scroll up menus/items in the touch screen. ■ Press the button's lower rim to scroll down. ■ Press the button's left or right rim to move the cursor left or right (when editing a contact number for example). ■ Press OK to select a menu/item/option.
4	Menu	Accesses menus: (1) Call Log (2) Contacts (3) Keys (4) Settings (5) Administration (6) Device Status
5	Voicemail	Retrieves voicemail messages.
6	Contacts	Press to open the 'Personal Directory'.
7	Redial	Accesses a list of recently dialed numbers; one can be selected to redial.
8	Kensington lock	Allows locking the device.
9	Transfer	Transfers a call.
10	Hold	Places an active call on hold.
11	Microphone	Allows talking and listening. The network administrator can disable it if required.
12	Alphanumerical Keypad	Keys for entering numbers, alphabetical letters and symbols (e.g., colons)
13	Speaker	Activates the speaker, allowing a hands-free conversation.
14	Headset	Activates a call using an external headset.
15	Mute	Mutes a call.
16	Volume	Increases or decreases the volume of the handset, headset, speaker, ring tone and call progress tones.
17	Cancel	Cancel an action, such as dialing a number, after beginning it.
18	Handset	A handset is the part of a phone you hold, containing a speaker to hear the caller and a microphone to talk into.

2.2.2 Rear View

The rear view of the phone is illustrated in the figure below and explained in detail in the accompanying table.

Figure 2: Rear View

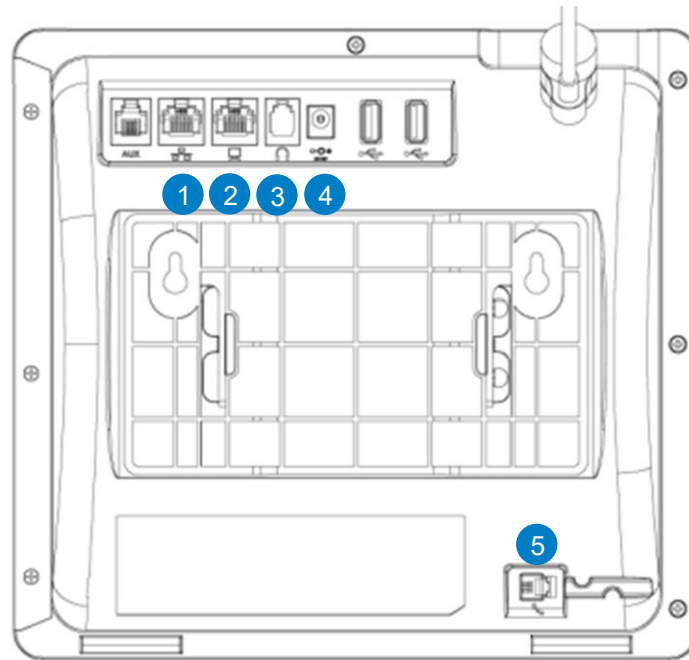







Table 2: Rear View Description

#	Label	Description
1		LAN Port (RJ-45, Uplink) – Connects the phone to the Ethernet LAN network (10/100/1000 Mbps). Supports Power over Ethernet (PoE) , allowing the phone to receive power directly through the Ethernet cable (via either a spare line or signal line), eliminating the need for a separate power adapter.
2		PC Port (RJ-45, Downlink) – Provides a pass-through Ethernet connection (10/100/1000 Mbps) to connect a PC or other networked device via the phone.
3		Headset Jack – RJ-9 port that connects to an external headset.
4	 DC12V	12V DC Power Jack – Used to connect the phone to an AC power adapter .
5		Handset Jack (RJ-9 Port) – Used to connect the handset to the phone.

2.3 Cabling

To cable phone:

1. Connect the short, straight end of the handset cord to the handset. Connect the longer straight end of the cord to the phone's handset jack.
2. (Optional) Connect a headset to the phone's USB port.
3. Connect the phone's power socket labelled DC 12V to the connector tip of the AC power adapter. Connect the two-prong AC adapter directly to the electrical wall outlet.
4. When the phone powers up, all the LEDs momentarily light up.
5. (Optional) Connect the phone's RJ-9 headset jack to a headset
6. Connect the RJ-45 PC port to a computer/laptop, using a CAT 5 / 5e straight-through Ethernet cable
7. Connect the phone's RJ-45 LAN port to your LAN network (LAN port or LAN switch/router), using a CAT 5 / 5e Ethernet cable.



If the LAN to which the phone is connected supports Power over Ethernet (PoE), no AC adapter is required; the phone receives power from the Ethernet network.



Prior to connecting power, refer to the Compliancy and Regulatory Information at www.audiocodes.com/library.

Figure 3: Cabling

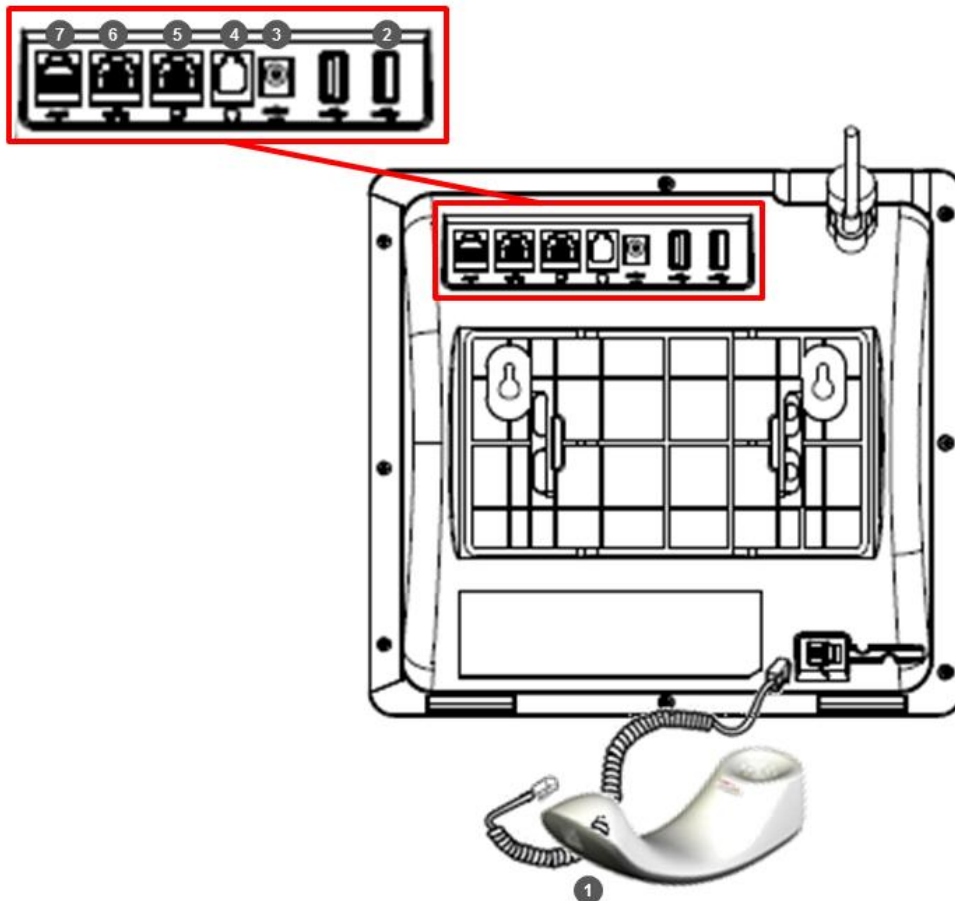

2.4 Mounting the Phone

The phone can be mounted on a:

- Desk (see Section 2.4.1 below)
- Wall (see Section 2.4.3)

See also <https://www.youtube.com/watch?v=oGe9STB9IFE> to assemble the base stand.

2.4.1 Desktop Mounting

This section describes how to mount the phone on a flat surface like a desk.

To mount the phone on a flat surface like a desk:

1. Off-hook the handset (if on-hook) and place the phone upside down, i.e., base-up, on your desktop.
2. On the phone's stand, identify outer notches.
3. On the phone's base, identify outer rails.
4. Invert the stand and align its outer notches with the base's outer rails.
5. Insert the stand's outer notches into the base's outer rails and slide the notches along the rails until the stand click-locks into the base.
6. Revert the phone and stand it on the desktop.

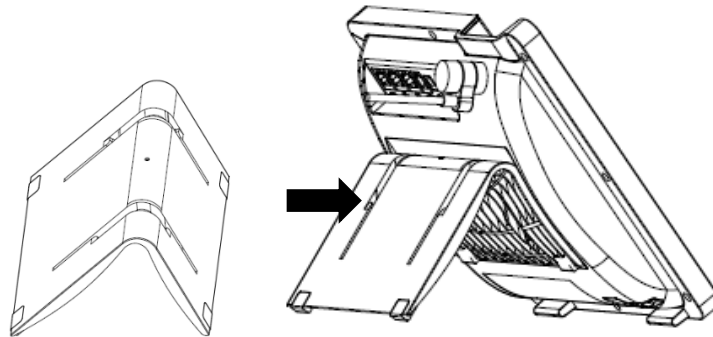

2.4.2 Mounting the Expansion Unit on a Desktop



Only applies to **C450HD** phone users with the Expansion Unit option.

A dedicated stand is supplied for the Expansion Unit. Its mounting mechanism is identical to the phone's (see the previous section for more information).

2.4.2.1 Routing the Handset Cable

The phone features a groove for routing the handset cable.

2.4.3 Wall Mounting

This section describes how to mount the phone on a wall.

To mount the phone on a wall:

1. Attach the stand of the phone for the purpose of a wall mounting:
 - a. Detach the base.

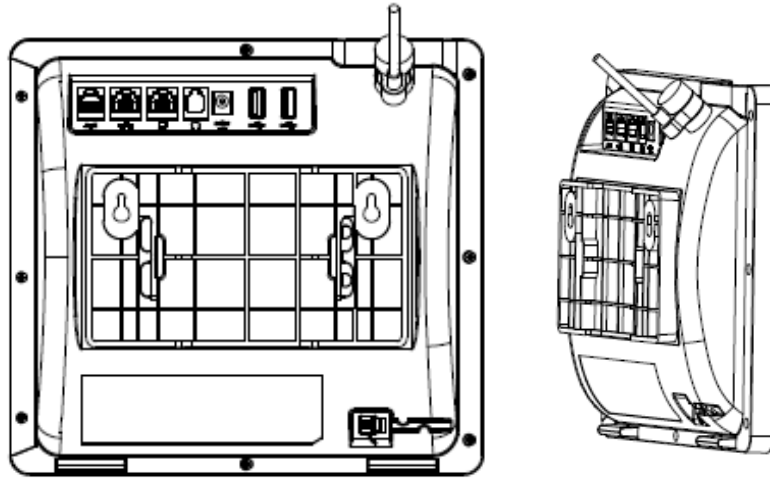

- b.** Attach it again as you did for a desktop mounting (see Section 2.4.1) only now make sure that it's flatly aligned to lie flush against the wall, i.e., slide the *inner rails* of the phone stand onto the phone base's inner notches.
- 2.** Connect the AC power adapter, LAN and PC/laptop cords.
- 3.** In the wall, drill two horizontal holes at a distance of 3 15/16 inches (100 mm) from one another, in line with the template.
- 4.** Insert two masonry anchors into the holes if necessary.
- 5.** Thread two screws (not supplied) into the two masonry anchors; ensure that the heads extend sufficiently (about 3/16 inch or 5 mm from the wall) for the phone stand's keyhole slots to hang on.
- 6.** Hang the phone stand's keyhole slots on these screws.

3 Getting Started

This section gets you started with the C450HD IP Phone. The phone features a touch screen, providing an intuitive, menu-driven user interface for configuring the device and viewing call information.

3.1 Getting Acquainted with the Phone's Screen

The figure below shows the touch screen in idle state.

Figure 4: Touch Screen in Idle State

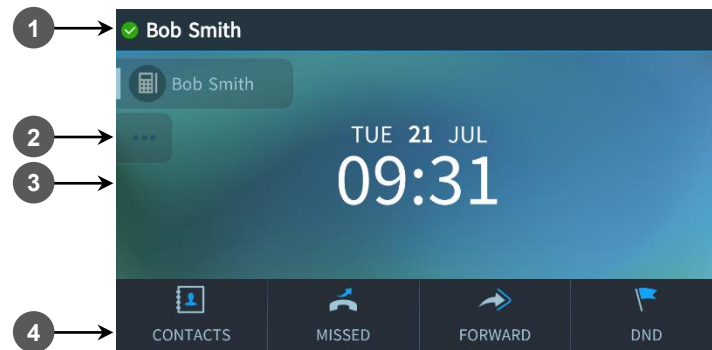

Screens images depicted in this document might vary slightly in appearance from the actual screen images on your phone.

Use the table below as reference:

Table 3: Touch Screen in Idle State

Reference	Description
1	Presence status: Available, Busy, Do not disturb.
	User name and phone number configured by your network administrator.
2	Programmable Key. Enables programming a key for a speed dial, key event, or discreet call.
3	Day, Date and Month, automatically retrieved from the Network Time Protocol (NTP) server, enabled by your network administrator.
	Time, automatically retrieved from the Network Time Protocol (NTP) server, enabled by your network administrator.
4	Softkeys. See Table 4 for softkey descriptions.

3.2 Softkeys

The table below describes the softkeys displayed in the touch screen. Press a softkey to activate.

Table 4: Softkey Descriptions

Softkey	Description
Missed	Displays missed calls.
Forward	Automatically forwards calls.
DnD	Do not Disturb (see Section 7.10 "Activating Do Not Disturb")
Contacts	Opens the 'Personal Directory'.
Call Log	Displayed after lifting the handset (for example).
Select	Identical to the hard OK key on the phone. Either can be used. Selects a menu or option.
A/a/1	Enables switching between input modes: abc, ABC, Abc or 123.
Save	Saves settings.
Cancel	Cancels the currently initiated call or configuration.
Dial	Displayed after a number is keyed, a directory contact is selected, or a logged call is selected.
Clear	Displayed after entering a digit of a phone number (for example). Deletes from right to left.
Call Menu	Displayed after dialing a number and it's answered, and after you answer a call.
Conf	Displayed (1) after a number is dialed and the call is answered on the other side and (2) after you answer a call. Pressing it displays the ADD PARTICIPANT screen or merge a call if there are two calls.
BXfer	Allows you transfer the call in a blind transfer. The softkey is displayed (1) after a number is dialed and the call is answered on the other side and (2) after a call is answered.
URL	Displayed after lifting the handset (for example). Enables calling a URL.
Detail	Displayed after selecting a call log (for example). If selected, the details of a logged call are displayed (Time, Date, etc.).
End	Displayed after pressing the Dial softkey (for example). Ends the call.
Back	Displayed after pressing the MENU key (for example). Returns to the previous screen.
Edit	Displayed after you select a contact to be edited (for example).
Delete	Displayed after pressing the MENU key and then selecting Call Log (for example).
Silent	Silences the ring. The softkey is displayed when the phone rings for an incoming call.
Reject	Rejects the call. The softkey is displayed when the phone rings, for an incoming call.
Accept	Answers the call. The softkey is displayed when the phone rings, for an incoming call.

3.3 Navigating the Phone Menu

The **MENU** hard key on the phone lets you configure settings and access information. Press it to view call logs, configure speed dials, customize phone settings, determine device status, perform administration and access 'Contacts'. Press the key to view the phone's Menu screen.

Figure 5: Phone Menus

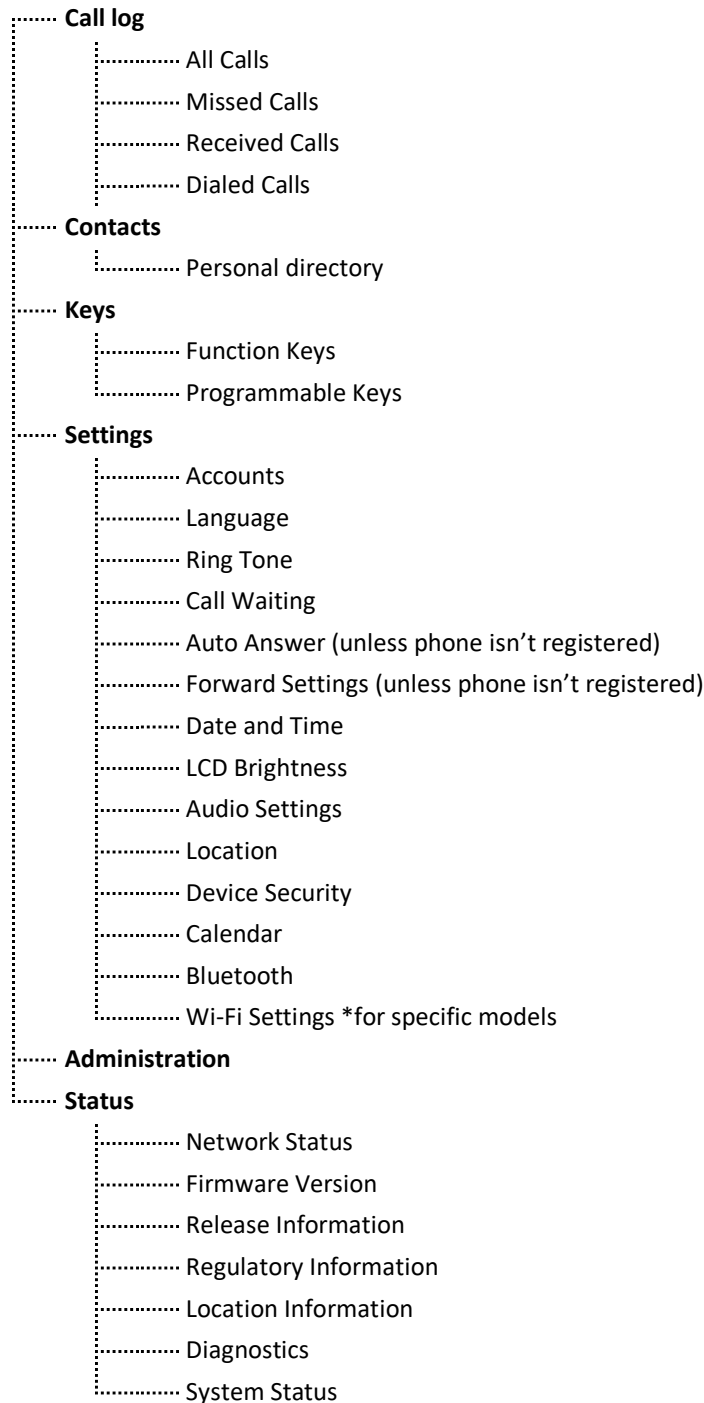

Administration is intended for network administrators only. It is password protected. See the *Administrator's Manual* for details.

To access the menu and menu items:

- Press the **Menu** softkey in the phone screen.

To navigate to menu items:

- After opening the menu, press the navigation control button's lower rim -OR- press the menu item's number, e.g., press **3** to navigate to **Keys Configuration**.

To select a menu or menu item:

- Press the navigation control's **OK** button.

To cancel and move to a previous menu level:

- Tap the **Back** softkey.

3.4 Inputting Data Using the Virtual Keyboard

The feature allows users to easily and effortlessly enter strings into fields in the phone's screens. Users will mainly use the virtual keyboard when:

Searching for contacts

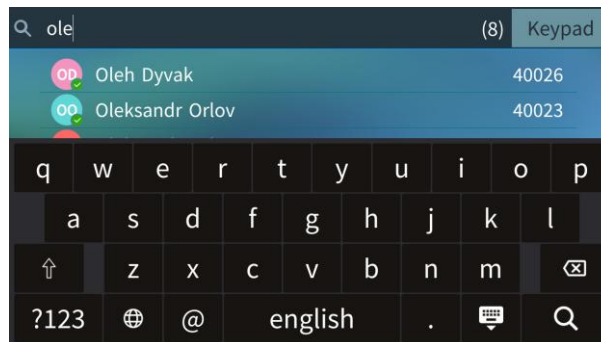

The feature is currently supported in all languages except Chinese and Japanese. The English language virtual keyboard will be displayed until these are supported.

When you press a key, the keyboard shows the key that was pressed in a popup above the key's physical location:

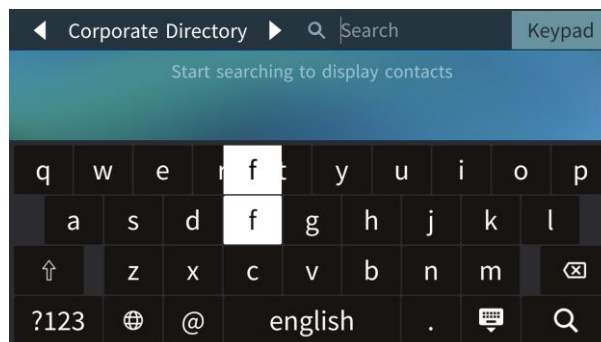

A popup for special characters facilitates an improved user experience:

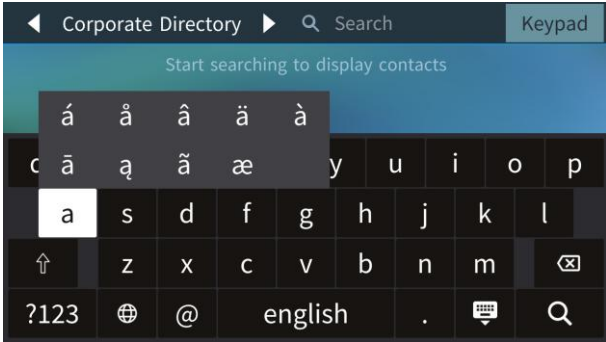

3.4.1 Changing Case

The keyboard allows you to enter upper case letters, lower case letters, combinations of these, numbers and symbols.

To change:

- Open the Personal Directory (press the **Contacts** softkey or **CONTACTS** button on the phone), for example, and then press **+New Contact**.

Figure 6: Personal Directory

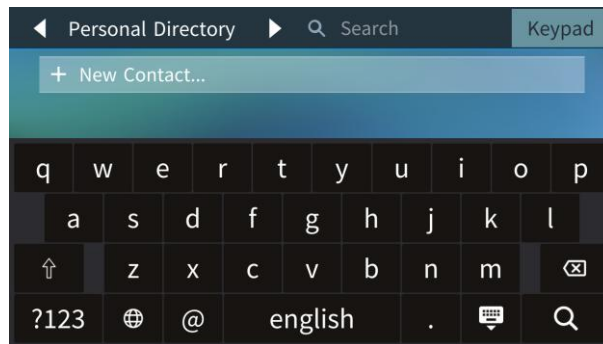

The virtual keyboard allows you to switch to symbols and to revert from symbols mode to letters or numbers mode.

Press to change to upper case or if you're in upper case, to lower case.

Press to change to symbols and numerals.

3.4.2 Switching Between Input Modes

3.4.2.1 Selecting an Alphanumerical Mode

The keypad lets you enter alphabetical letters, numbers or symbols, and to switch between them.

To select a number, letter or symbol (e.g., lower case letters):

1. Open the Personal Directory (press the **CONTACTS** button on the phone).

Figure 7: Personal Directory

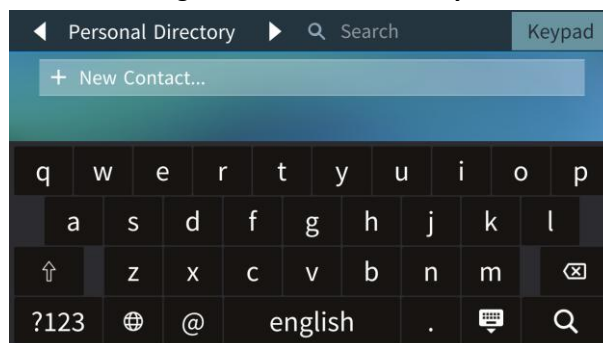

2. Press the 'enter' symbol in the lower right corner of the virtual keypad to remove the virtual keypad and then press the revealed **Input** softkey.

3.5 Inputting Data Using Multi-Tap

Each number key from 2-9 corresponded to three or four letters. To type a specific letter, you must press the numbered key multiple times. For example, to type "c," you press the "2" key three times.

To input Data Using Multi-Tap

1. Open the Personal Directory (press the **CONTACTS** button on the phone).
2. Press the revealed **Input** softkey and choose letter case or numbers from the mode menu.

Figure 8: Input Softkey

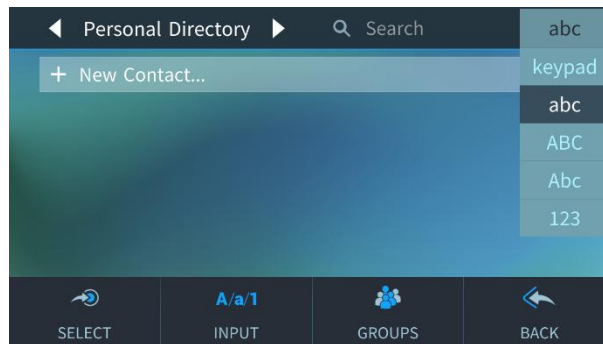

You can also access the mode menu by pressing the # key on the keypad. Press repeatedly to navigate.

3. From the **mode menu**, navigate to and select the desired input mode:
 - **abc** = lowercase letters
 - **ABC** = uppercase letters
 - **Abc** = first letter uppercase, the rest lowercase
 - **123** = numerical mode (i.e., numbers)
4. Select **abc** (for example), then use the keypad to enter letters:
 - Press the **2** key once to enter **a**
 - Press the **5** key three times to enter **l** (*once = j, twice = k, three times = l*)
 - Press the **2** key once again to enter another **a**
 - Press the **6** key twice to enter **n** (*once = m, twice = n*)

3.5.1 Switching between Letters and Numbers

The keypad allows you to enter upper case letters, lower case letters and numbers, and to switch from one mode to another.

To enter a contact's name (for example):

1. In the Add Contact screen, press the # key on the keypad.

Figure 9: Switching between Letters | Numbers

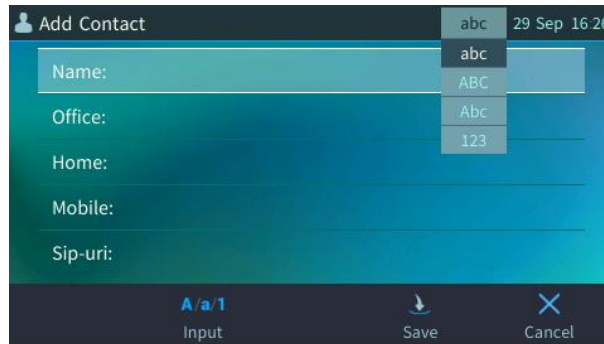

2. Press the # key successively to navigate to and select the mode:
 - **abc** = lower case letters
 - **ABC** = upper case letters
 - **Abc** = first letter upper case, the rest lower case
 - **123** = numbers
3. [For example] Select **Abc** mode and then on the keypad, press the **2** key; **A** is entered. Press the **5** key three successive times; **l** is entered (once produces **j**, twice produces **K**). Similarly, enter **a** and **n**.



3.5.2 Switching to Symbols

The keypad allows you to switch to symbols and to revert from symbols mode to letters or numbers mode.

To enter a symbol (e.g., dot or @ or hyphen):

1. Press the **#** key repeatedly until **abc** appears. *(This step is required.)*
2. Press the **1** key on the keypad. The first press enters a **period (.)**.
3. Continue pressing the **1** key successively to cycle through available symbols. The sequence typically includes: **. → \ → @ → ; → : → # → \$ → % → ^ → & → !**

Symbol	Explanation	Symbol	Explanation	Symbol	Explanation
.	Dot	?	Question mark	{	Open parenthesis
\	Backslash	+	Plus	}	Close parenthesis
@	At	-	Hyphen	[Open square parenthesis
;	Semi-colon	_	Underscore]	Close square parenthesis
:	Colon	~	Approximates	"	Double quotation marks
#	Pound	*	Star sign	'	Single quotation mark
\$	Dollar	=	Equal sign	>	Greater than
%	Percentage		Separator	<	Less than
^	Caret	(Open parenthesis	,	Comma
&	Ampersand)	Close parenthesis	/	Forward slash
!	Exclamation mark				

Note that the asterisk (*) symbol is entered directly using the star key.

Example:

To type the password **Abc123!** on a keypad:

1. Press the **#** key repeatedly until **Abc** appears.
2. Enter **A** by pressing the **2** key **once**.
3. Enter **b** by pressing the **2** key **twice**.
4. Enter **c** by pressing the **2** key **three times**.
5. Press the **#** key repeatedly until **123** appears.
6. Enter **1** by pressing the **1** key **once**.
7. Enter **2** by pressing the **2** key **once**.
8. Enter **3** by pressing the **3** key **once**.
9. Press the **#** key repeatedly until **abc** appears.
10. Enter **!** by pressing the **1** key repeatedly until **!** appears.



4 Performing Basic Phone Operations

This section describes basic phone operations:

4.1 Using Audio Devices

You can use any of the following audio devices on the phone for speaking and listening:

- **Handset:** To make a call or answer a call, lift the handset off the cradle.
- **Speaker** (hands-free mode). To activate it, press the speaker key during a call or when making a call. To deactivate it, press the speaker key again.
- **Headset** (hands-free mode). When talking on the phone, you can relay audio to a connected headset. To enable it, press the headset key. To disable it, press it again.

You can easily change audio device during a call.

To change from speaker/headset to handset:

- Activate speaker/headset and pick up the handset; the speaker/headset is automatically disabled.

To change from handset to speaker/headset:

- Off-hook the handset and press the speaker/headset key to activate the speaker/headset. Return the handset to the cradle; the speaker/headset remains activated.

To change to a Bluetooth headset:



- Press the hard headset button on the phone. If for example more than one headset is connected to the phone (analog, USB and/or Bluetooth), long-press the button and in the Select Audio Device screen that opens, select USB /analog /Bluetooth.

To change to a USB headset:

- Press the hard headset button on the phone. If for example more than one headset is connected to the phone (analog, USB and/or Bluetooth), long-press the button and in the Select Audio Device screen that opens, select USB /analog /Bluetooth.

4.2 Managing Calls

The screen that is displayed after dialing provides the following information:

- The name of the calling (in the figure below it is Adele Vance)
- The number (or name) of the calling party
- Outgoing call  icon, or Incoming call  icon
- The called party's presence status (in the screen figure it's  Away, Be Right Back)
- The name of the called party (if the name is listed in the phone directory)
- The number of the called party (or contact name if listed in the phone directory)

Screen indications:

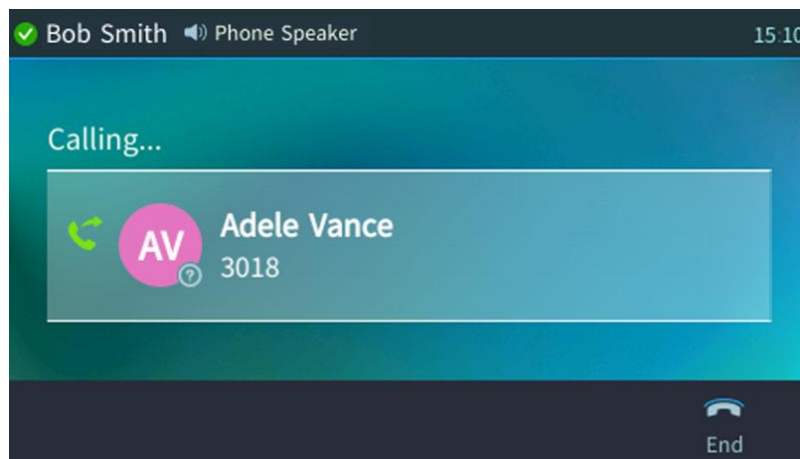

The phone plays a ring-back tone indicating to the caller that the called party's phone is ringing.

To end dialing a call before it's answered:

- Press the **End** softkey or the speaker key.



For advanced dialing using the phone directory, see Section 6.12 "Managing your Personal Directory". To configure a Speed Dial, see Section 6.14 "Function/Programmable Key as a Speed Dial".

4.2.1 Dialing

This section describes dialing options:

To dial a regular-digits phone number:

1. On the keypad, key the digit of a regular phone number; the touch screen displays the digits in the New Call field.



To delete entered digits (from right to left), press the **Clear** softkey.
To cancel the call, press the **Cancel** softkey.

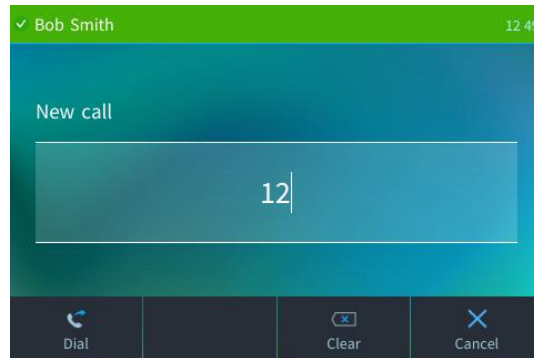

2. Do any of the following:
 - a. Don't do anything; dialing is automatically performed after a few seconds.
 - b. Press the **Dial** softkey; dialing is performed.
 - c. Pick up the receiver; dialing is performed.
 - d. Press the **Speaker** key; dialing is performed.
 - e. [If you switched on speaker/headset before keying in the number] Press the # hard key on the phone after keying in the number, to dial the number *immediately*.

To dial a URL:

1. Press the speaker key or lift the handset; the touch screen displays the New Call field and the **URL** softkey:



2. Press the **URL** softkey and enter a URL address.



To delete entered digits (from right to left), press the **Clear** softkey.
To cancel the call, press the **Cancel** softkey.
See Section 3.4 for how to switch letters, numerals and symbols.



3. Press the **Dial** softkey to call the URL.

4.2.2 Redialing

You can redial a number you previously dialed.

To redial:

1. Press the **REDIAL** hard key on the phone; the Dialed Calls screen is displayed, listing in chronological order, recently dialed numbers:
2. Navigate and select the phone number to redial
3. Press the **Dial** softkey or press the **OK** key.

4.2.3 Dialing a Missed Call

The phone logs all missed calls. The screen in idle state displays the number of missed calls.

To dial a missed call:

1. Press the **Missed** softkey displayed in the idle screen.
2. Select the missed call to dial.
3. Press the **Dial** softkey or press the **OK** key.



A call can be made in the same way from *any* of the Call Logs.

4.3 Answering Calls

The phone indicates an incoming call as follows:

- The screen displays the incoming call icon  together with the caller's phone number (or contact name if listed in the phone directory):

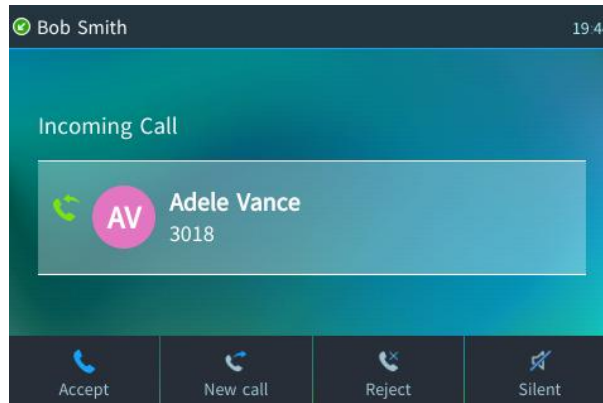



- Phone rings.
- Ring LED flashes green.

To answer:

- Pick up the handset -OR- press the headset key (make sure the headset is connected to the phone) -OR- press the speaker key -OR- press the **Accept** softkey (the speaker is automatically activated).

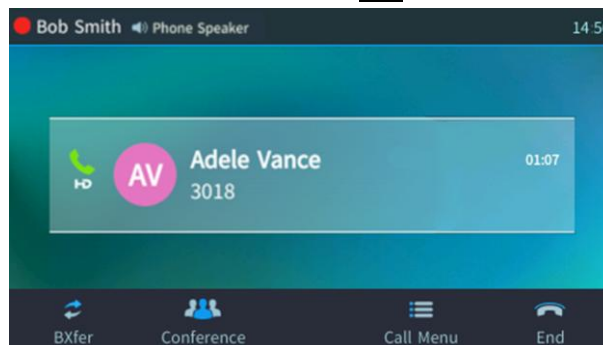
When you answer, the screen displays the  icon with the caller's details and call duration:



- **HD** in the screen indicates a high-definition call (using a wideband voice coder).
- When two incoming calls occur simultaneously, the names of the calling parties appear in the screen and the adjacent incoming call icons flash. If a user is in a call and a third-party calls, the name of the calling party appears on the screen and the adjacent incoming call icon flashes.
- If a contact is in a call and they are listed in your phone's Speed Dial keys, the Speed Dial key icon indicates that the contact is in a call. If that contact is in a call with another contact listed in your phone's Speed Dial keys, the Speed Dial key icons of both the calling contact and the called contact change to indicate that they are in a call.
- When two calls come in simultaneously, the names of the calling parties appear on the screen indicated by the incoming call icon . If a user is in a call and a third-party calls, the name of the calling party appears on the screen indicated by the incoming call icon .

4.4 Rejecting Incoming Calls

An incoming call can be rejected if for example you are busy or unavailable to take the call. The caller on the other side will hear a busy tone from your phone.

To reject an incoming call:

- Press the **Reject** softkey.

To send an incoming call to voicemail:

- When the phone rings to alert to a call, wait the timeout period and the call will be forwarded to voicemail.

4.5 Silencing Incoming Calls

An incoming call's ringing can be silenced if for example a colleague is consulting with you in your office, and you don't want the disruption. The caller on the other side will hear regular ringing.

To silence the ringing of an incoming call:

- Press the **Silent** softkey.



- Answer a silenced call by pressing the **Accept** softkey or picking up the handset.

4.6 Making a New Call Even Though a Call is Coming in

A new call can be made even though a call is coming in, typically needed when it's more important and pressing to make a new call than to accept an incoming.

To make a new call when a call is coming in:

1. In the Incoming Call screen, tap the **New Call** softkey.
2. In the New Call screen, enter the destination number to call and then tap the **Dial** softkey.
3. When the destination number answers, you can toggle to the *calling* party and reject or accept them.

4.7 Ending an Established Call

To end an established call:

- Return the handset to the phone cradle if it was used to take the call -or- press the headset key -or- press the speaker key -or- press the **End** softkey.

4.8 Viewing the Call Log

The phone logs calls that are missed, received and dialed.

To view missed calls:

- Configure a Programmable Softkey with a 'Missed calls' key event or select **Menu > Call Log > Missed calls**.

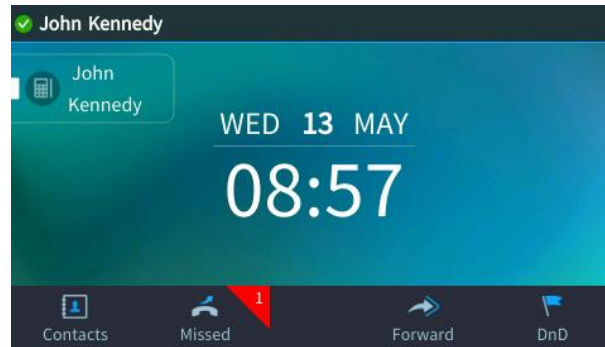

After viewing, the indication disappears from the screen. The next time a call is missed, the indication will reappear.

To view call history:

1. Open the Call Log screen (**MENU** hard key > **Call Log**).
2. In the Call Log screen, navigate to and select the call log you require.

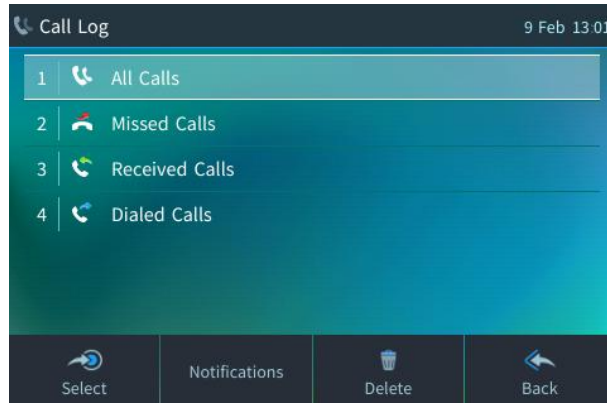

- **All Calls:** Calls that were missed, received, and dialed
 - **Missed Calls:** Calls that were not answered
 - **Received Calls:** The most recently answered calls
 - **Dialed Calls :** The most recently dialed phone numbers
3. Select the option you want (e.g., Missed Calls).
 4. Press the softkey you need:
 - **Dial:** Dials the selected logged call.
 - **Save:** Saves the selected logged call information in the Personal Directory (for adding a contact in the directory, see Section 6.12, [Managing your Personal Directory](#)).
 - **Detail:** View the select logged call details.

The Call Details screen displays the following logged call information:

- ◆ **Number:** The selected phone number logged
- ◆ **Time:** The time the call was logged
- ◆ **Date:** The date on which the call was logged
- ◆ **Duration** The duration of the call (if answered)



- The call history lists are stored from the newest to oldest entries. The maximum number of entries for each call history type is 20. Once this maximum is attained, the oldest entry is deleted and replaced with the new entry.
- The call history lists are saved on a daily basis. In the case of a power outage, some of the received information may be lost.
- After viewing Missed Calls (by pressing the Missed softkey), the indication in the idle screen disappears. It'll reappear the next missed call.

4.9 Using Multiple Lines

Your phone supports up to 30 lines. Each is configured with its own extension number. The figure below displays the idle screen of a phone set up with two lines whose extensions are '1002' and '1010'. Current line indicator displays a "White" thick line at begin of programmable key label.

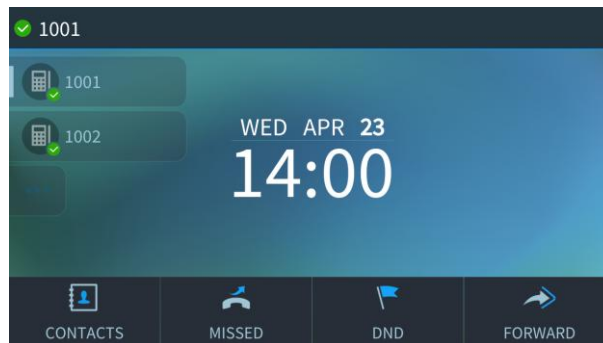

Only your phone/network administrator can configure lines. See the *Administrator's Manual* for detailed information.

4.9.1 Choosing a Line

You can select a line to use. The screen displays a bar above the extension number of the line currently being used. Until you change this line, all new calls are made on it.

To change lines:

1. Make sure that the LCD is in idle state and that no calls are established. View the two configured lines displayed in the screen. View the bar above the currently used line.
2. Navigate to and select the other line; the bar moves above it; all new calls will now be made on it.

4.9.2 Making a Call on a Line

To make a call on a line:

1. When the screen is in idle state, raise the handset or press the key of the first digit of the number to call; the NEW CALL screen is displayed.
2. Enter the number of the person to call or select a contact from the Directory and tap the **Dial** softkey; the dialed number is called and the line on which the call is made is indicated in the screen.

4.9.3 Making Two Calls on a Line

To make two calls on a line:

1. On line 1 call **A**. After establishing this call, select **Call menu** and tap the **New Call** softkey; the call with **A** is automatically put on hold and the NEW CALL screen is displayed.
2. Enter **B**'s phone number or select their entry in the directory and tap the **Dial** softkey. **B** answers.
3. To toggle between **A** (on hold) and **B**, press the navigation control's upper and lower rim (see Section 4.9.6).

4.9.4 Making Multiple Line Calls

Your phone supports multiple line calls. Calls can run simultaneously on each line.

Example scenario:

1. Line 1 calls **A**
2. Line 2 calls **B**

To make a multiple line call:

1. When the screen is in idle state, navigate to and select the extension line.
2. Lift the handset; in the NEW CALL screen displayed, enter the phone number or select a contact from your directory.
3. Tap the **Dial** softkey. The called party answers.
4. Tap the **New Call** softkey; the called party is automatically put on hold and you're prompted to enter a phone number or select a contact.
5. Press the navigation control's upper or lower rim to navigate to another extension line.
6. Make another call exactly like you made the first (on hold) but on the other extension line: Enter a phone number or select a contact and tap the **Dial** softkey.
7. To toggle between the first called party who's on hold and the active called party, press the navigation control's upper and lower rim (see below).

4.9.5 Toggling Between Multiple-Line Calls

After making calls on two different lines, you can toggle between them. When using two lines, one line is active while the other is on hold. Toggling between lines therefore involves putting the currently active call on hold and resuming the previously held call.



Indicates an active line.

A call on hold is indicated like this:



To toggle between multiple-line calls:

- Navigate to and select the conversation to resume and tap the **Resume** softkey or the **OK** hard key to resume the call.

4.9.6 Toggling Between Calls on the Same Line

You can toggle between calls on the same line. How you toggle depends on whether the first-placed call is active or the second-placed call is active.

To switch from the first-placed call to the second-placed call:

- Navigate to and select the second-placed call and then tap the **Resume** softkey; the first-placed call is automatically put on hold.

To switch from the second-placed call to the first-placed call:

- Navigate to and select the first-placed call and then tap the **Resume** softkey; the second-placed call is automatically put on hold.

4.9.7 Ending Calls

You can only end calls that are active, i.e., not on hold.

To end a call:

1. Make sure that the call is active and not on hold.
2. Tap the **End** softkey or the **SPEAKER** key.

4.10 Paging a Group

After configuring a paging group and a paging dial on the phone (see section 6.16, [Configuring a Function/Programmable Key for Paging](#)), you can page others in your group, and they can page you, to announce a change of venue, for example. You can use the speaker, handset or headset as the audio device to page your group.

To page others in your group:

1. Press the Function Key or Programmable Key that you configured for paging the group.

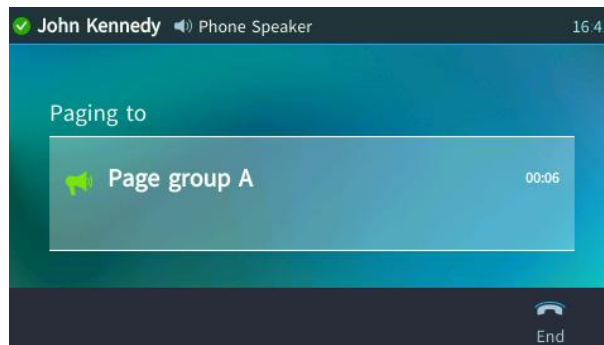

2. Pick up the receiver and make the announcement, or talk directly into the speaker.

4.10.1 Receiving an Incoming Paging Call

Any other user configured in your group can page you.

To receive a paging call from another user configured in your group:

- View in your phone's screen which group the paging call is coming from and listen to the incoming paging call.

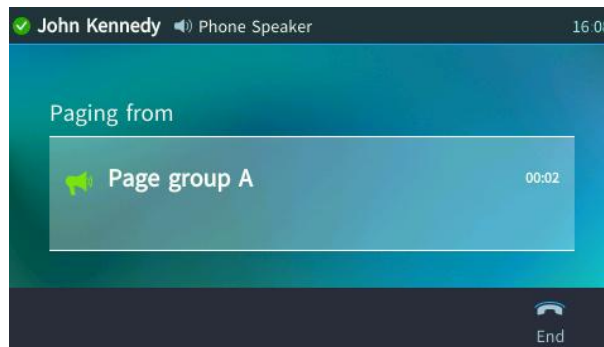

4.10.1.1 If Paged when in a Regular Call and Barge-in is Disabled

If you're in a call when paged and the 'Barge-in' feature was disabled by your network administrator, you're prompted to accept/reject the paged call.

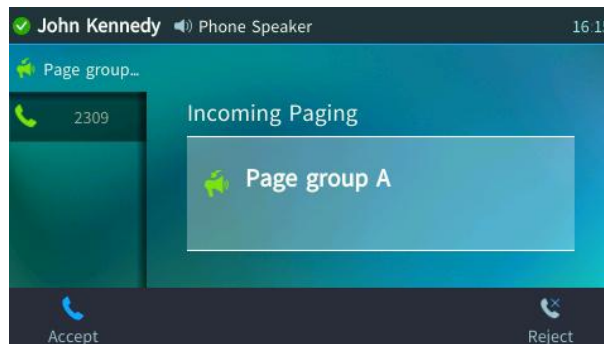

- If you tap the **Accept** softkey; the regular call is put on hold and the paged call is heard.

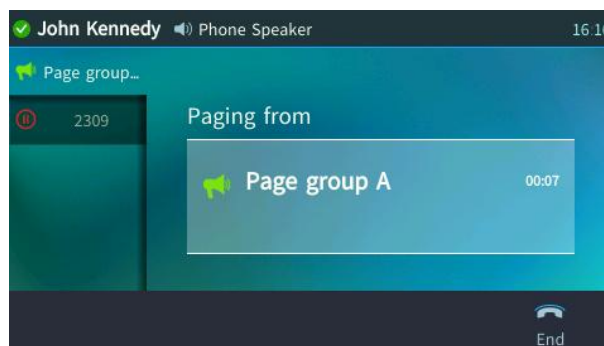

If you'd have tapped **Reject**, the paging wouldn't have barged in on the regular call.

- When you've heard the paging call, tap the **End** softkey and then the **Resume** softkey to resume the regular call that was put on hold.

4.10.1.2 If Paged when in a Regular Call and Barge-in is Enabled

If you're in a call when paged and the 'Barge-in' feature was enabled by your network administrator, the paging call barges into the regular call which is put on hold.

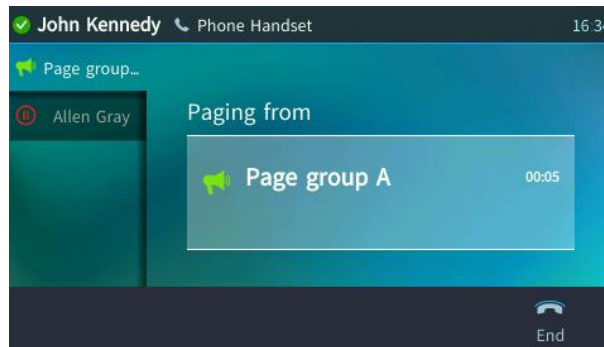

- Tap the **End** softkey and then the **Resume** softkey to resume the regular call.

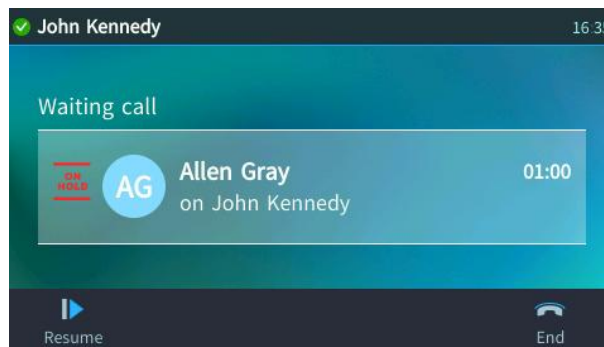

4.11 Using the Phone's Automatic Lock Feature

The phone is capable of automatically locking after a configured period of time to secure it against unwanted (mis)use. If left untouched for 10 minutes (default), it automatically locks and becomes inaccessible to anyone who does not know its lock code.

- Incoming calls are allowed, but outgoing calls need the lock code.
- Without the lock code, users cannot access the Call Log, Calendar and Corporate directory, but they can call preconfigured emergency numbers.



For the phone's automatic locking feature to be available to users, the network administrator must enable it. See the *Administrator's Manual* for details.

After the network administrator has enabled the feature, you need to enable it on the phone (if it isn't enabled already).

When signing in for the first time, the user is prompted for the lock code. After entering a code, e.g., **123456**, confirming and saving it, the phone goes into idle state and locks after 10 minutes.

To enable the lock feature on the phone:

1. Press the MENU key, press the **Settings** item and scroll to and select **Device Security**.



2. In the Device Security screen, select **Locking the Device**, press **Select**, and then select **Enabled**.

**To disable the lock feature on the phone:**

1. Press the MENU key, press the **Settings** item and scroll to and select **Device Security**.
2. In the Device Security screen, select **Locking the Device**, press **Select**, and then select **Disabled**.

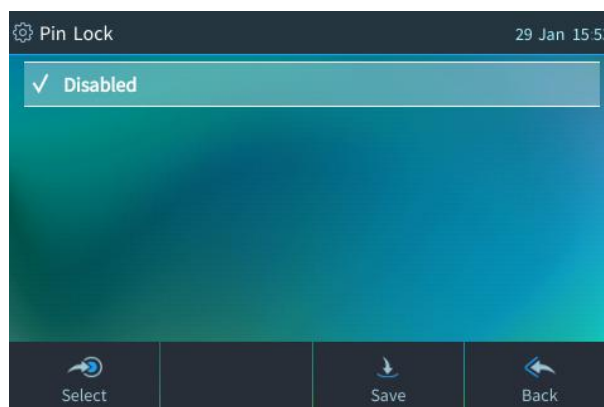

4.11.1 Unlocking a Locked Phone

If the locking feature is enabled, the phone automatically locks after a configured period of time, securing it against unwanted (mis)use. If left untouched for 10 minutes (default), it automatically locks and is inaccessible to anyone who doesn't know its lock code. After a phone locks:

- Outgoing calls cannot be made
- Call Log, Calendar and Corporate Directory cannot be accessed

Your network administrator, if necessary, can allow making emergency calls and other capabilities even though the phone is locked. See the next section for more information.

To unlock a locked phone:

- When prompted for a lock code, enter a code, e.g., **123456**, and then press **OK**; the phone enters idle state.

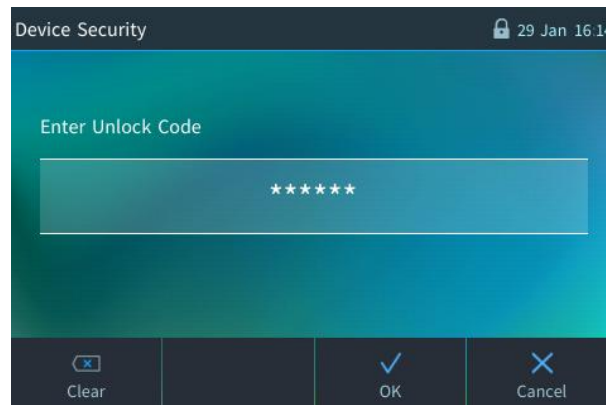

4.11.2 Manually Changing the Lock Code

The lock code can manually be changed as an extra security measure.

To manually change the code:

1. Press the **MENU** hard key on the phone, select **Settings** and then scroll down to select **Device Security**.
2. In the Device Security screen, select **Change Unlock Code**.

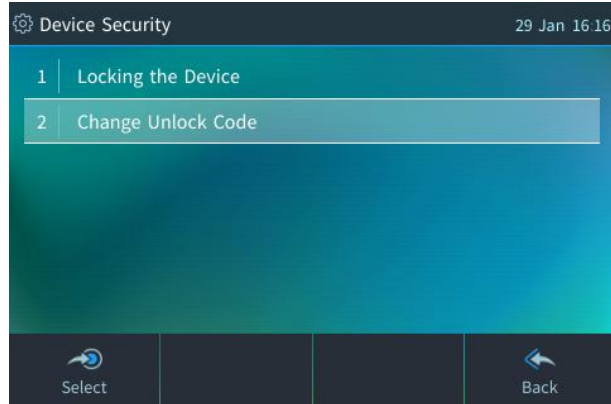

3. Enter the new unlock code, press the **Next** softkey and re-enter the code.

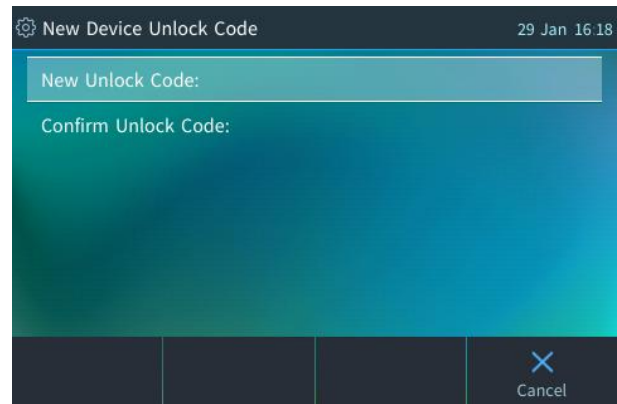
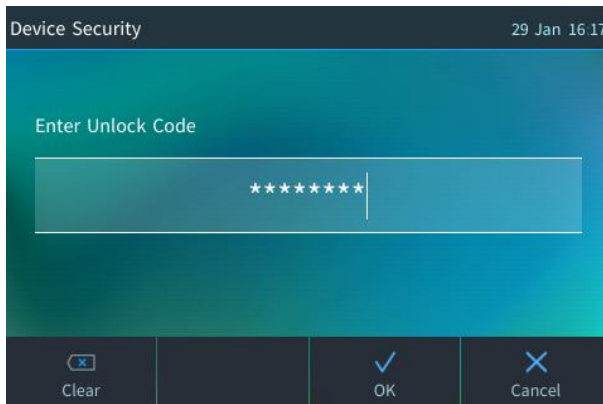

4. Press **Save**.

5 Virtual Sidecar for Shared Lines

5.1 Overview

The C450HD **IP Phone** features a **Virtual Sidecar**, offering multiple Programmable Keys to enhance call management efficiency. This functionality allows users to navigate and manage multiple lines, active calls, and shared lines effectively.

Figure 10: Virtual Sidecar



Using up and down arrow keys allows you to scroll through up to 8 virtual keys. Pressing the Programmable Key on the right will activate the virtual key. The Programmable Keys tabs can display lines, speed dialing, call park, etc. Press on one of the four programmable keys to select a line on the virtual sidecar.

Figure 11: Virtual Key Icons

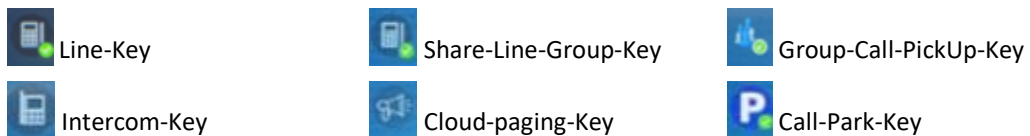

For more information about using the Virtual Sidecar, see section 5, "[Virtual Sidecar for Shared Lines](#)".

Supported Devices:

- Virtual Sidecar can be enabled or disabled (default: disabled).

Key Features:

- Up to 8 Functional/Programmable Keys.
- Tabs for managing **Lines**, **Calls**, and **Shared Lines**.

5.2 Navigating the Virtual Sidecar

Using up and down arrow keys allows you to scroll through up to 8 virtual keys. Pressing the Programmable Key on the right will activate the virtual key. The Programmable Keys tabs can display lines, speed dialing, call park, etc. Press on one of the four programmable keys to select a line on the virtual sidecar.

Figure 12: Example of Line-Key, Intercom-Key, Share-Line-Group-Key, and Cloud-paging-Key.

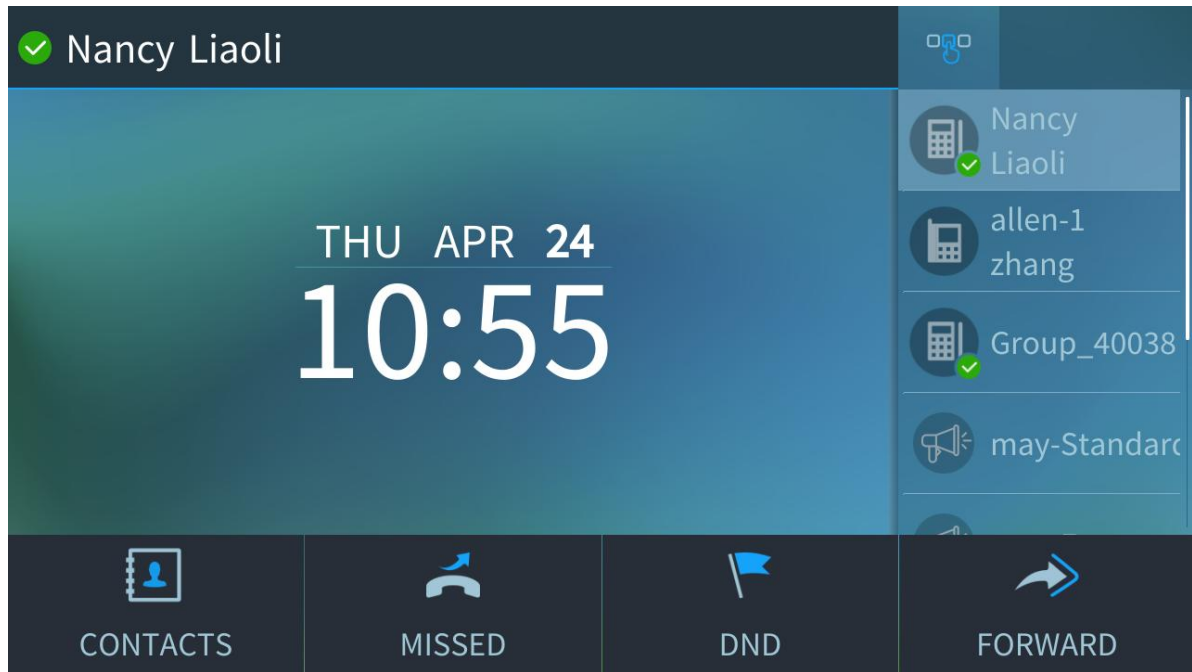

5.3 Managing Calls

5.3.1 Incoming and Outgoing Calls

Incoming and outgoing calls are displayed in the **Call List tab**, and incoming calls cause the incoming call Functional Key to flash green.

To view active calls:

1. Press the **Call List Tab**.
2. Select a call by pressing the **Functional Key** of the call to bring any call to the main screen.

Figure 13: C450HD: Virtual Sidecar with incoming call

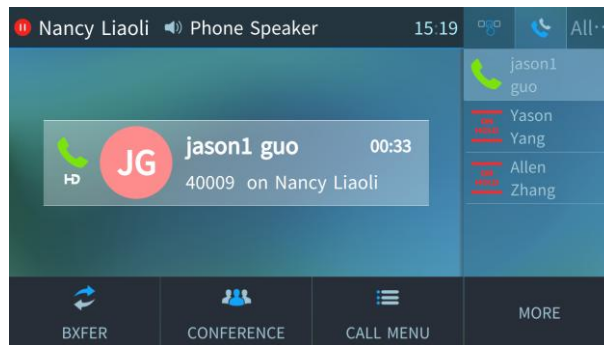

5.3.2 Managing Multiple Calls

To select from multiple calls:

1. Press the **Right Hard Key** to switch to the **Call List Tab**.
2. Navigate through calls using **Up/Down Arrow Keys**.
3. Pressing the **Programmable Key** brings the call to the main screen.
4. Actions available: **Hold, Resume, End**

Figure 14: Example of Managing Multiple Calls (one outgoing and two on hold) in call list tab

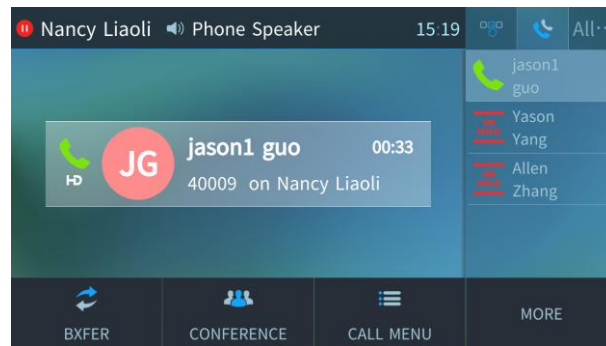

5.3.3 Shared Line Management

Figure 15: Example of a Shared line tab

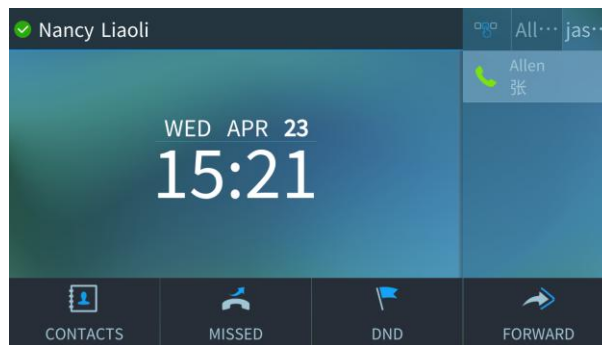

To select a Shared Line:

- Press the **Right Hard Key** to select the shared line tab. Each shared line displays its own tab with active calls.

LED Indicators:

- **Flashing Green:** Incoming call.
- **Steady Red:** Active or held call on a shared line.

To Pick up a Shared Line Call:

- Press the **Red Programmable Key** for the shared line call.
- The call will appear on the main screen for pickup.

Figure 16: Shared Line Call Pickup



6 Configuring and Customizing Your Phone

See the *Administrator's Manual* for information about configuring a line.

6.1 Displayed Messages

Messages indicating processes in progress, displayed in the screen, include:

Table 5: Displayed Messages Indicating Processes In Progress

Message	Description
Initializing	Initializing
Discovering LLDP	Discovering VLAN using Link Layer Discovery Protocol (LLDP)
Discovering CDP	Discovering VLAN using Cisco Discovery Protocol (CDP)
Acquiring IP	Acquiring an IP address from a DHCP server
Initializing Network	Initializing the network
Downloading Firmware File	Downloading a firmware file
Upgrading Firmware	Upgrading the phone's *.img firmware
Updating Configuration File	Upgrading the phone's *.cfg configuration file

6.2 Changing the Screen Language

The phone supports multiple languages. English is the default.

To change the default:

1. Open the **Languages** screen (**MENU** hard key > **Settings** > **Language**).
2. Navigate to and select the language you require.

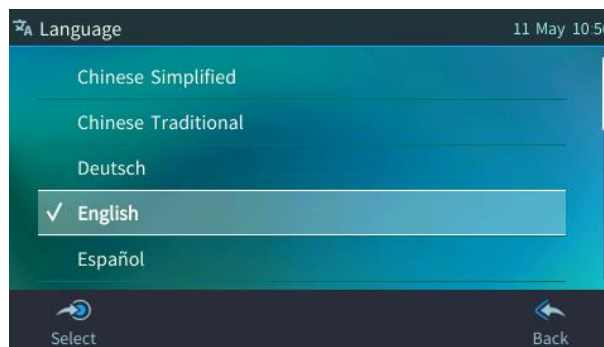

3. Press the **Save** softkey to save the setting.

6.3 Configuring Lines and Wi-Fi

The phone can connect to an Access Point via Wi-Fi. The Wi-Fi interface can be used when the phone is installed in an environment free of LAN/cables, to perform VoIP calls over Wi-Fi.

To connect to Wi-Fi:

1. In the phone's main menu, press the **Networks** icon -or- in the 'Settings' menu, navigate to and select the **Wi-Fi** option. If an Ethernet cable does not connect the phone to a LAN port:



2. Alternatively access Wi-Fi settings via the MENU hard key > **Settings** > **Wi-Fi Settings**.

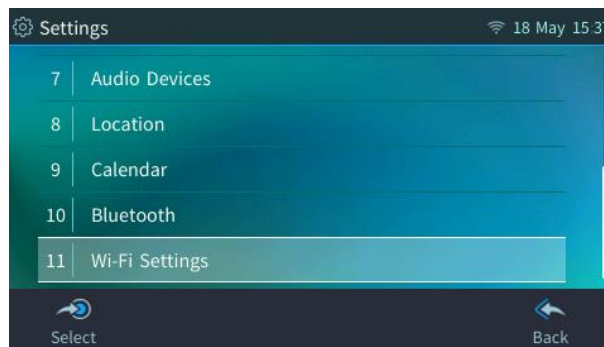

3. Enable/disable Wi-Fi by pressing the navigation button's right/left rim (Default: Disabled).

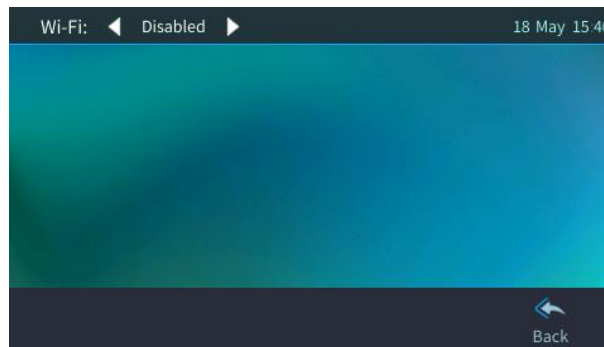

4. After enabling Wi-Fi, the phone indicates 'Searching for networks...' The phone then displays available Wi-Fi Access Points. If necessary, press the **Refresh** softkey to display more options.



5. After selecting a Wi-Fi Access Point, configure Access Point parameters.

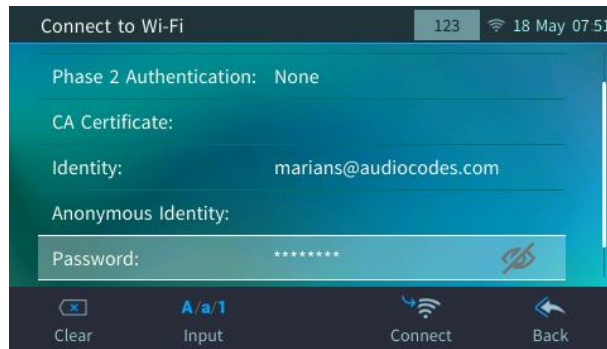

6. After configuring the Wi-Fi parameters, press the **Connect** softkey and wait about 20-30 seconds for the phone to connect to Wi-Fi and receive an IP address; the Wi-Fi icon is then displayed in the uppermost right corner of the screen:

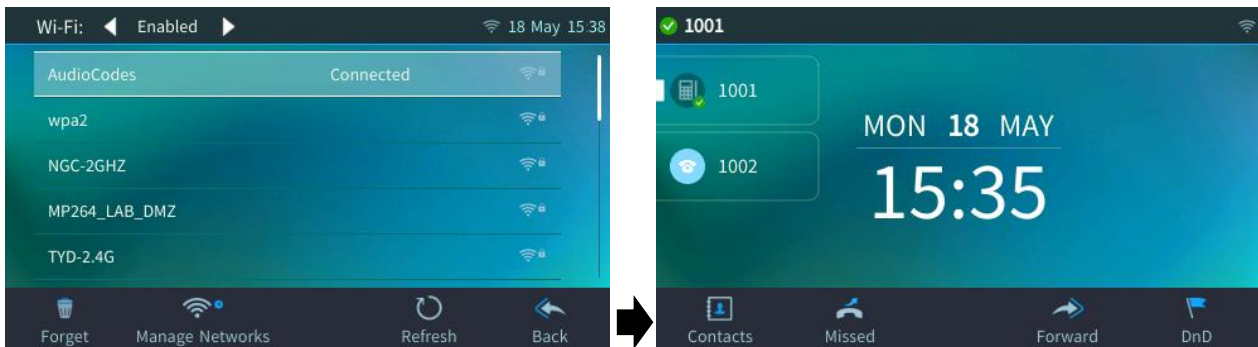

7. Determine Wi-Fi status (network name, authentication method and Wi-Fi signal strength) from the Wi-Fi Network Info screen (**Device Status > Wi-Fi**).

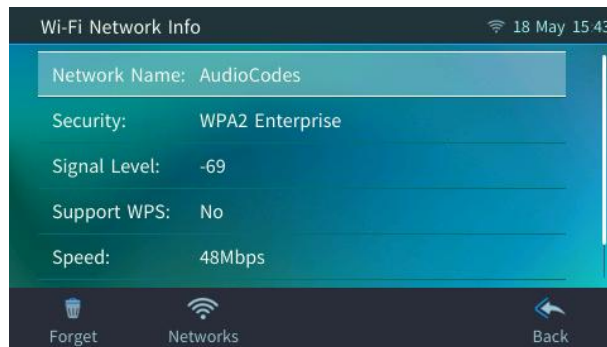

- An icon indicating Wi-Fi signal strength is also displayed, on the screen's upper bar.
- If a Wi-Fi connection has been set up and established, it will be used even if a LAN connection exists.



6.4 Selecting Ring Tone

You can choose from a selection of ring tones to indicate incoming calls.

To select a ring tone:

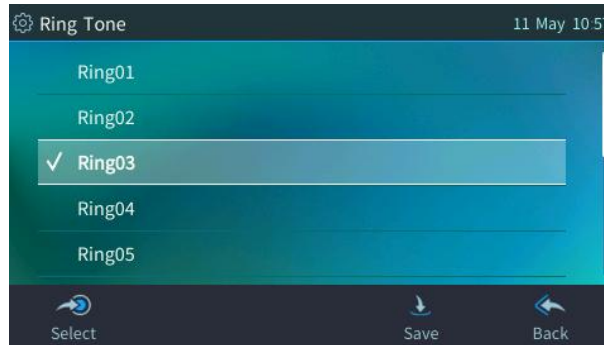
1. Open the **Ring Tone** screen (**MENU** hard key > **Settings** > **Ring Tone**).



2. Navigate to and select a ring tone (a sample of each ring tone is played as you navigate through the list).
3. Set ring tone volume by pressing the VOL  or VOL  key:
A few seconds after adjusting the volume level the Ringer Volume indication is hidden.
4. Press the **Select** softkey to apply your settings.
5. Press the **Save** softkey to save your settings.

To assign a ring tone per line extension:

1. Open the **Ring Tone** screen (**MENU** hard key > **Settings** > **Ring Tone**).

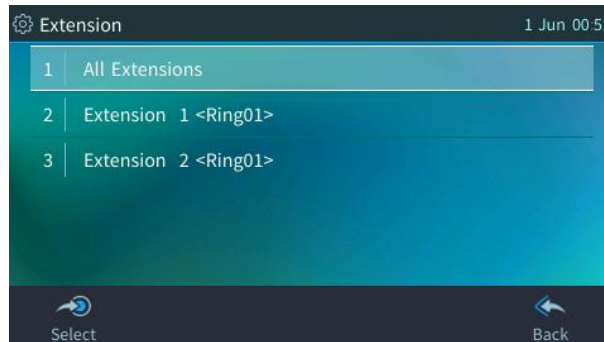

2. Navigate to and select the line extension for which to configure a ring tone.
3. In the Ring Tone screen that opens, select the ring tone of your choice and then press the **Save** softkey.

6.5 Enabling Call Waiting

You can enable or disable the call waiting feature.

To enable or disable call waiting:

1. Open the **Call Waiting** screen (**MENU** hard key > **Settings** > **Call Waiting**).

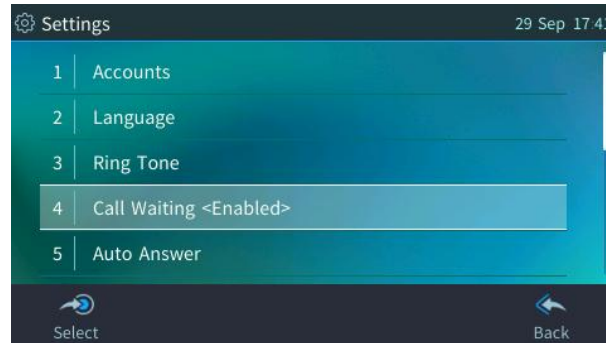

2. Navigate to and select:
 - Select **Disable** to disable call waiting
 - Select **Enable** to enable call waiting
3. Press the **Select** softkey to apply your settings.
4. Press the **Save** softkey to save your settings.

6.6 Managing Simultaneous Incoming Calls

If two calls simultaneously come in on a phone, or if a user is in a call and a third-party calls, the phone's screen displays the situation in a graphically user-friendly way.

- Simultaneous incoming calls:

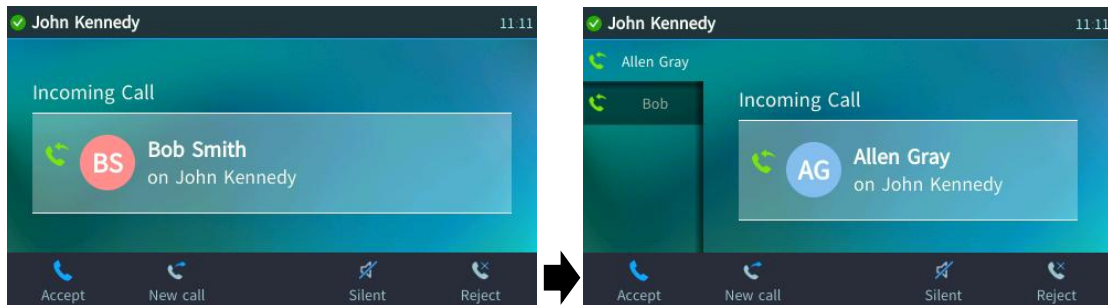

- When one of the incoming calls is answered:



- When a phone is in a call and another call comes in:



Visual indication on the device when the call comes in:

- The LED of the Programmable Key configured as an extension does not light up when receiving the first incoming call. However, if a second or subsequent call comes in on that extension, the LED flashes green (if there is an available BLF for the line extension and the server supports it).
- The LED of the Programmable Key that is configured as an extension is illuminated red after a call that comes in on that extension is answered (if there's an available BLF for the line extension and the server supports it).
- The LED in the upper right corner of the device flashes green when a call comes in.

6.7 Configuring Call Forwarding

This feature enables you to automatically redirect an incoming call to another phone number, including a mobile phone number, if a user-defined condition is met, e.g., if the line is busy. All Call Forwarding options can be configured from the phone.



If your enterprise deployed BroadSoft's BroadWorks server, your network administrator can control the Call Forwarding feature on the phone from the server. For more information, see the *Administrator's Manual*.

To configure call forwarding:

1. Open the **Automatic Forward** screen (MENU hard key > **Settings** > **Forward settings** -or- press the **Forward** softkey when the screen is in idle state):

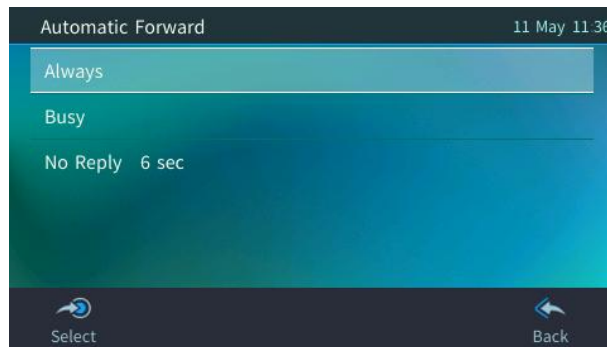

2. In the Automatic Forward screen, select either:
 - **Always:** incoming calls will always be forwarded
 - **Busy:** incoming calls will be forwarded when the user is using the phone
 - **No Reply 6 sec:** incoming calls will be forwarded if the user doesn't answer after a specified number of seconds; the default is **6** but you can configure up to **98** seconds.
3. After the selection, configure the phone number to which you want the calls to be forwarded.

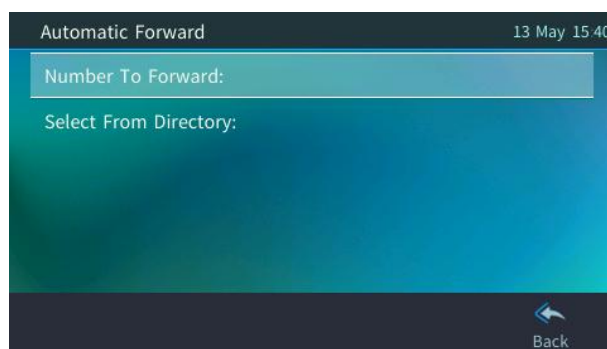

4. Alternatively, navigate to and select the **Select From Directory** option and then choose the contact to whose number you want the calls to be forwarded.
5. Press the **Start** softkey that's then activated; you're returned to the idle screen; in the idle screen, view a check mark in the corner of the **Forward** softkey; calls will automatically be forwarded to the configured number.

You can also see the 'forwarding' flag on this screen.

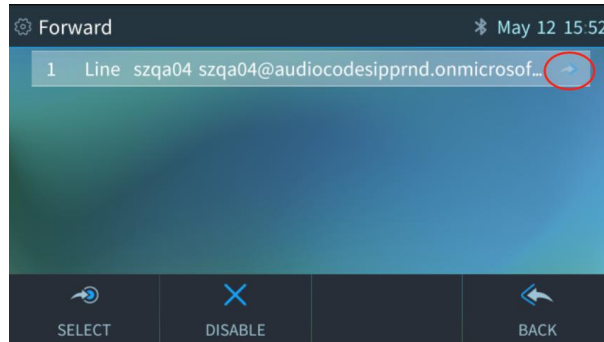

6. You can configure forward 'Busy' and 'No Reply' at the same time. In the example below, incoming calls will be forwarded to 80073 when phone is busy, and if phone is in idle state, calls will be forwarded to 80074 after ringing for 12 seconds.

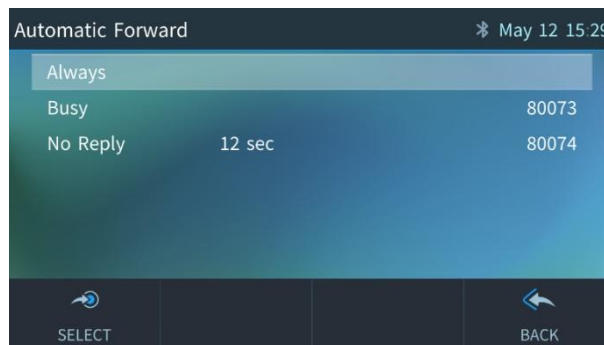

To configure call forwarding on multiple lines:

1. Open the **Forward** screen (press the **Forward** softkey when the screen is in idle state).

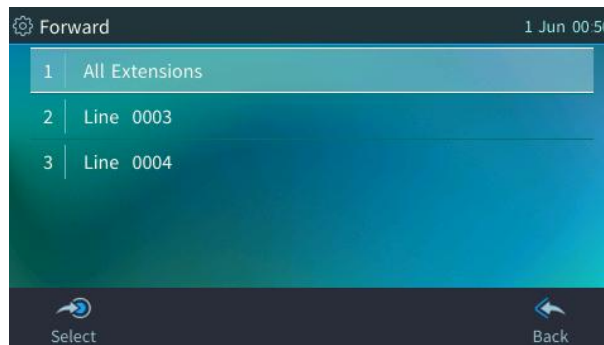

2. Navigate to and select the line extension on which to configure call forwarding; the Automatic Forward screen is displayed, as shown in the previous instruction set.
3. Configure call forwarding on that line extension and then proceed to the next line extension on which you want to configure call forwarding.

To stop call forwarding:

- When the phone is in idle state, press the **Forward** softkey; the check mark in the corner disappears.
- For multiple lines, you can select a specific line or select **All Extensions** and then press the **DISABLE** softkey; the forward icon  on right will disappear (based on your selection).

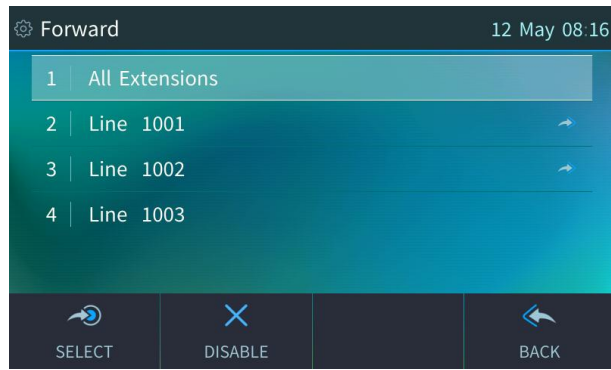

6.8 Configuring Time and Date Settings

This section shows how to make sure the NTP server is enabled, configure enabling / disabling obtaining time zone from the DHCP server, configure the time format and configure the date format.

6.8.1 Making Sure the NTP Server is Enabled

You can manually set date and time displayed on your phone but if a Network Time Protocol (NTP) server is deployed and enabled by your administrator, date and time are automatically retrieved over the Internet from the server and manually setting them will not be possible. You'll then receive a message **Set by NTP**.



- It's recommended to implement an NTP server. If the phone's 'NTP server' setting is set to 'Disabled', inform the network administrator. Only the network administrator can change it. It must be set to 'Enabled' for date and time to be automatically retrieved from the NTP server. System administrators can see the *Administrator's Manual* for detailed information.
- If date and time are manually set, the settings are not retained after rebooting the phone or powering off. You will need to manually reset date and time if you reboot or power off.

To make sure the NTP server is enabled:

1. Open the Date and Time screen (**MENU** hard key > **Settings** > **Date and Time**).

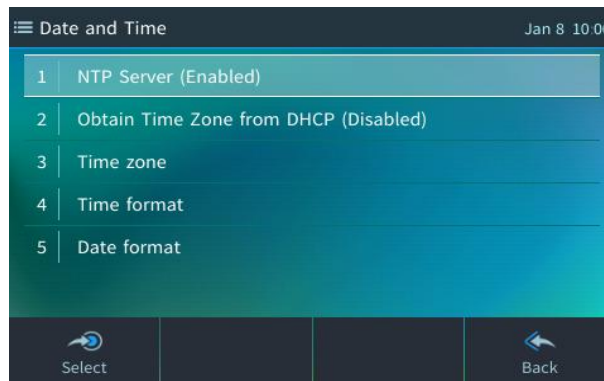

2. Select **NTP Server**.
3. If not already 'Enabled', notify your network administrator.



To configure the NTP server, see the *Administrator's Manual*.

To enable/disable obtaining time zone from the DHCP server:

1. Open the Date and Time screen (**MENU** hard key > **Settings** > **Date and Time**).
2. In the Date and Time screen shown above, select **Obtain Time Zone from DHCP**.

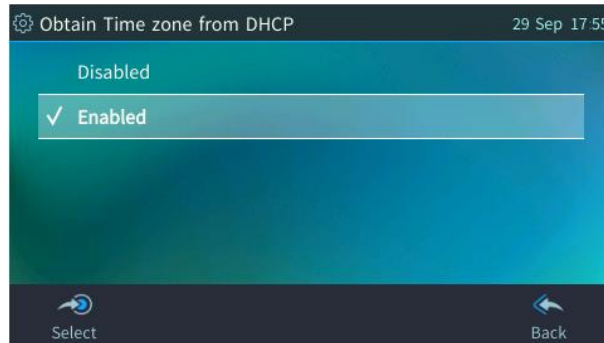

If 'Obtain Time Zone from DHCP' is set to **Disabled**, inform the network administrator. Only the network administrator can change the setting on the phone because it is password secured.

To configure the time format:

1. Open the Date and Time screen (**MENU** hard key > **Settings** > **Date and Time**).
2. Navigate to and select the **Time format** option and then select the format of your choice.

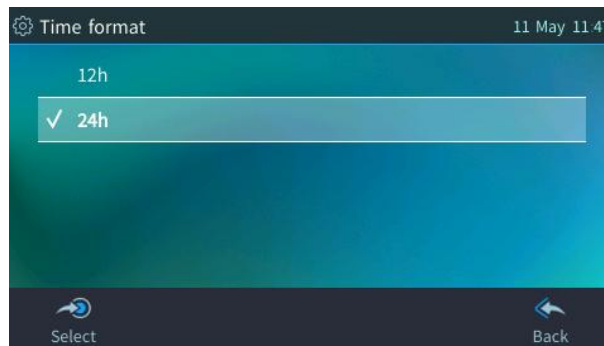
**To configure the date format:**

1. Open the Date and Time screen (**MENU** hard key > **Settings** > **Date and Time**).
2. Navigate to and select the **Date Format** option and select the format of your choice.

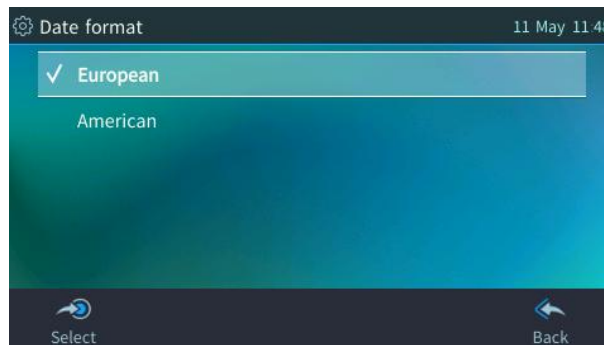

6.9 Configuring Screen Brightness

The phone's screen supports different brightness levels. You can choose the level that suits you best.

To configure screen brightness:

1. Open the LCD Brightness screen (**MENU** hard key > **Settings** > **LCD Brightness**).

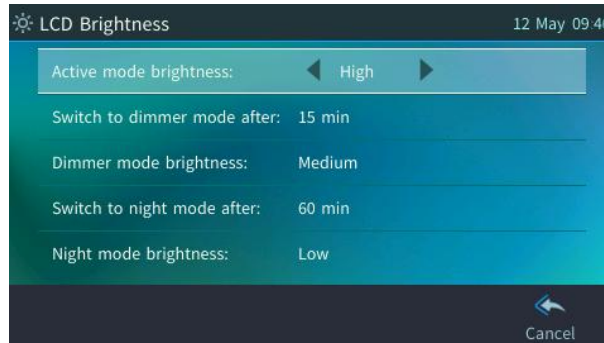

2. Navigate down to an option and then navigate to the level that suits you best. Use the table below as reference.
3. Press the **Save** softkey to apply the setting.

Table 6: Screen Brightness Options

LCD Brightness Option	Description
Active mode brightness	Defines the brightness of the screen when it's in 'active mode', which is for example after a calendar reminder pops up in your screen or when a call comes in or after you press a key on the dial pad. <ul style="list-style-type: none"> ■ Low ■ Medium ■ High (default)
Switch to dimmer mode after	Defines the timeout of 'active mode', in minutes. If it expires, the screen changes to 'dimmer mode' (see the next description). Configure either 15 (default), 30, 45 or 60 minutes.
Dimmer mode brightness	Defines the brightness of the screen when it's in 'dimmer mode'. The screen changes to 'dimmer' mode after the timeout configured for 'active mode' expires (see above). You can configure either: <ul style="list-style-type: none"> ■ Low ■ Medium (default) ■ High
Switch to night mode after	Defines the timeout of 'dimmer mode', in minutes. If it expires, the screen changes to 'night mode'. Configure either 30, 60 (default), 90 or 120 minutes.
Night mode brightness	Defines the brightness of the screen when it's in 'night mode'. The screen changes to 'night mode' after the timeout configured for 'dimmer mode' expires (see above). You can configure either: <ul style="list-style-type: none"> ■ Low (default) ■ Medium ■ High

6.10 Configuring a Default Audio Device

Users can configure a default audio device. This is the device that's used when the user presses the **Accept** key to answer calls or when the user dials using speed dial.

The default audio device is the speaker.

To change the default:

1. Open the Select Audio Device screen (MENU key > **Settings** > **Audio Settings** > **Audio Devices**)

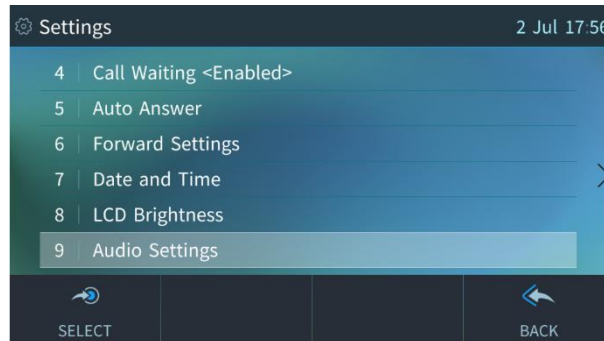

2. Navigate to and select **Analog Headset** or other connected USB/Bluetooth entities and then **Set as Default**.



6.11 Adjusting Volume



The phone allows you to adjust

- Ring volume
- Tone volume (e.g., dial tone)
- Handset volume
- Speaker volume
- Headset volume

6.11.1 Adjusting Ring Volume

The volume of the phone's ring alerting you to an incoming call can be adjusted to suit personal preference.

To adjust ring volume:

1. When the phone is in idle state, press the VOL  or VOL  key; the Ringer Volume bar is displayed on the screen.

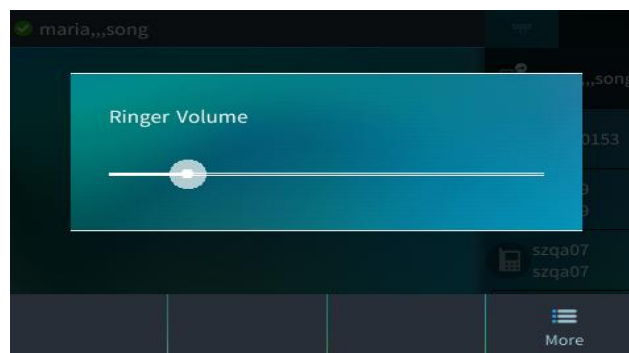

2. After adjusting, the Ringer Volume level disappears from the screen.



You can alternatively press the upper and lower rim of the navigation control button to increase or decrease ring volume, tones volume or call voice volume. When you press the **OK** on the navigation control button, the volume screen disappears.

6.11.2 Volume Mixer Control of multiple streams

Ability to change the volume of different phone streams (e.g., Ringer, Tones, Music, etc.)

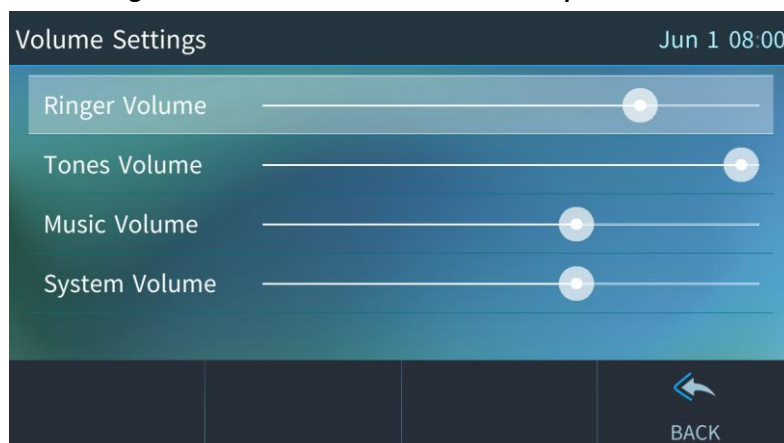

Figure 17: Volume Mixer Control of multiple streams



6.11.3 Adjusting Tones Volume

The phone's tones, including dial tone, ring-back tone and all other call progress tones, can be adjusted to suit personal preference.

To adjust tones volume:

1. Off-hook the phone (using handset, speaker or headset).
2. Press the VOL  or VOL  key; the Tones Volume bar displays on the screen.

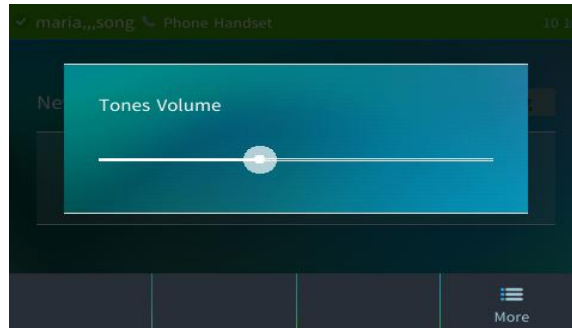



3. After adjusting, the Tones Volume bar disappears from the screen.

6.11.4 Adjusting Handset Volume

The volume of the handset can be adjusted to suit personal preference. The adjustment is performed during a call or when making a call. The newly adjusted level applies to all subsequent handset use.

To adjust handset volume:

1. During a call or when making a call, make sure the handset is off the cradle.
2. Press the VOL  or VOL  key; the Handset Volume bar is displayed on the screen.

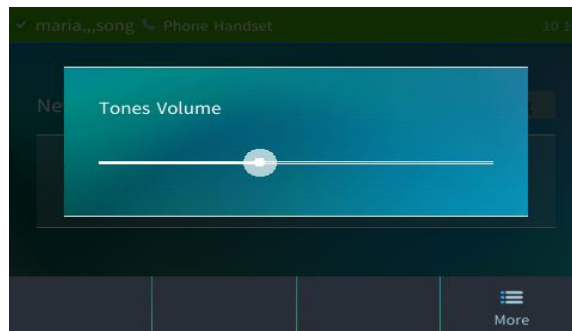



3. After adjusting, the Handset Volume bar disappears from the screen.

6.11.5 Adjusting Speaker Volume

The volume of the speaker can be adjusted to suit personal preference. It can only be adjusted *during a call*.

To adjust the speaker volume:

1. During a call, press the speaker hard key on the phone.
2. When the phone is in idle state, press the VOL  or VOL  key; the Speaker Volume bar is displayed on the screen.

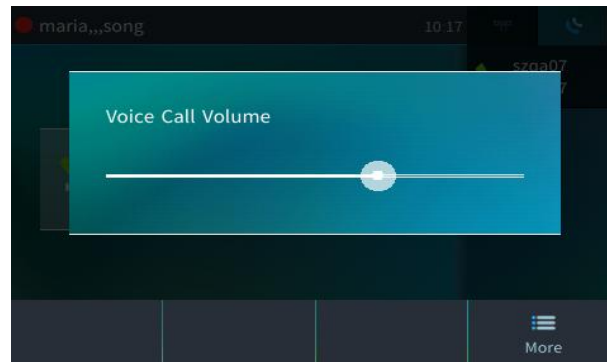



3. After you have completed adjusting the volume, the Speaker Volume bar disappears from the screen.

6.11.6 Adjusting Headset Volume

The volume of the headset can be adjusted to suit personal preference. It can only be adjusted *during a call*.

To adjust the headset volume:

1. During a call, press the headset hard key on the phone.
2. Press the VOL  or VOL  key; the Headset Volume bar is displayed on the screen.

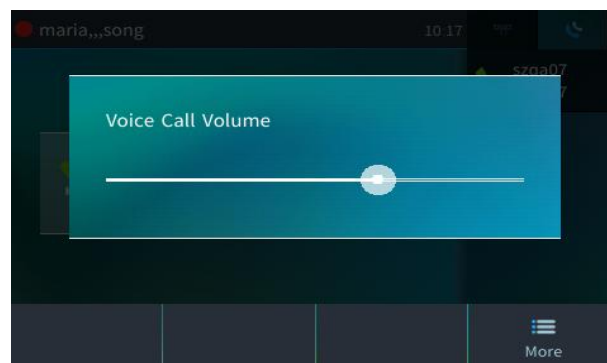

3. After you have completed adjusting the volume, the Headset Volume bar disappears from the screen.

6.12 Managing your Personal Directory

The phone supports the Personal directory.



- You can add, edit and delete contacts in the Personal directory.
- You can add a maximum of 1,000 contacts to your Personal directory. After adding a contact, you can call the contact directly from the directory. If you receive an incoming call from a contact listed in the directory, the screen displays the name listed.
- The Personal directory displays the presence status of contacts (depending on server BLF support).
- If you assign a speed dial key to a contact, you can press it to call them.

6.12.1 Adding a Contact to the Personal Directory

The home number, office number, mobile number and/or SIP URI of a contact can be added to the Personal Directory. You can also configure a speed dial to place calls quickly to the contact (see Section 6.14 [Function/Programmable Key as a Speed Dial](#)). After adding the contact, you can search for them in the group, dial them, edit their contact information or delete them.



You can add a maximum of 1,000 contacts to your Personal Directory. After adding a contact, you can call the contact directly from the directory. If you receive an incoming call from a contact listed in the directory, the touch screen displays the name listed.

To add a contact to the Personal directory:

1. Open the Personal directory (press the CONTACTS hard key on the phone).

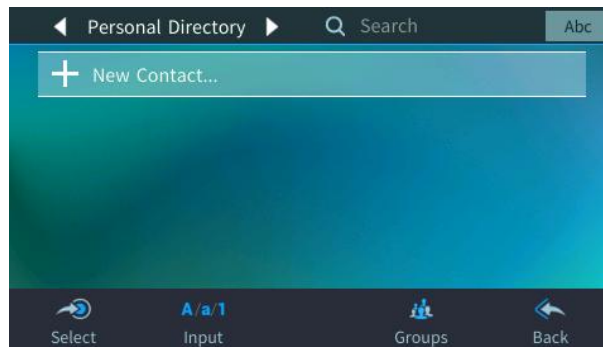

2. Select **+ New Contact**.

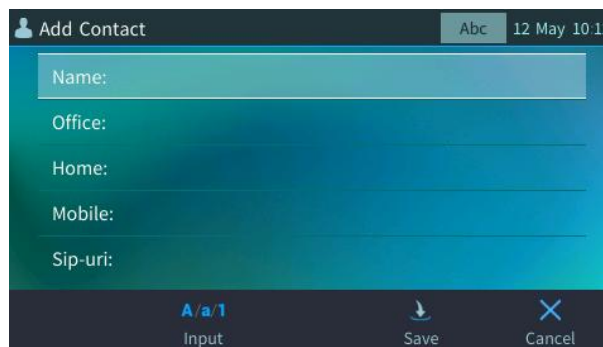

3. In the 'Add Contact' screen, key in the 'Name' of the new contact.
4. Navigate down and key in the new contact's office phone number.
5. [Optionally] Navigate down and key in the new contact's home and mobile numbers as well.

6. [Optionally] Navigate down and enter their SIP URI, e.g., mike.dubb@audiocodes.com. This option can be useful to you if you don't know their phone number.
7. Press the **Sp. Dial** softkey to assign a speed dial key if required.

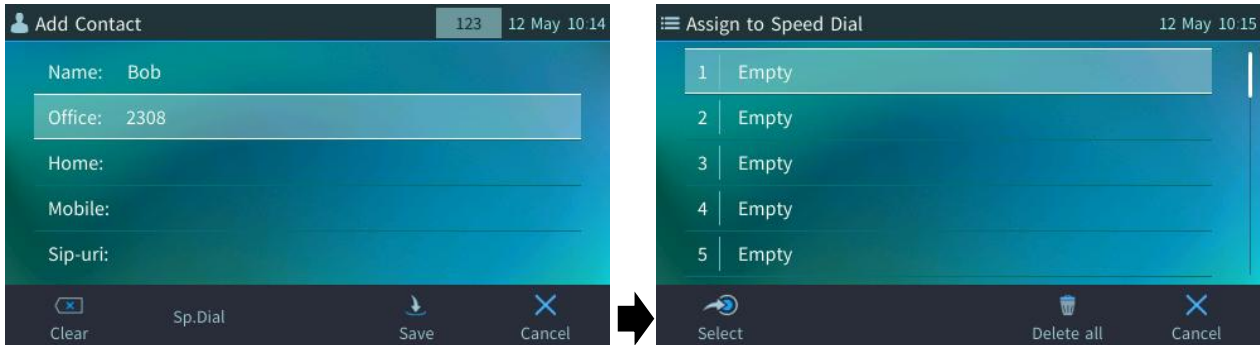

8. Navigate to and select the first 'Empty' speed dial, and then save it; the speed dial key is displayed in the phone's sidecar.

6.12.2 Editing Contact Information

Information about a contact in the Personal directory can be edited. This is important if a contact changes their phone number, for example.

To edit contact information:

1. Open the Personal directory (press the CONTACTS hard key on the phone), navigate to the name of the contact whose information you want to edit and then press the **OK** hard key on the phone.

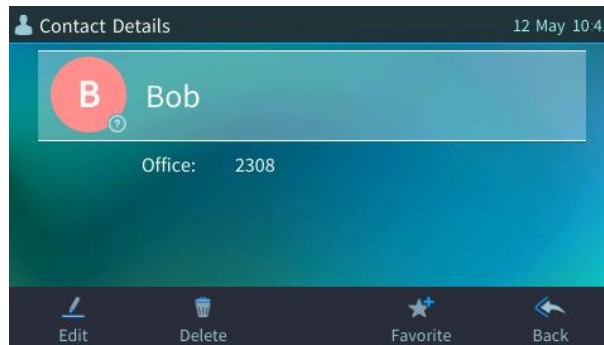

2. Press the **Edit** softkey.

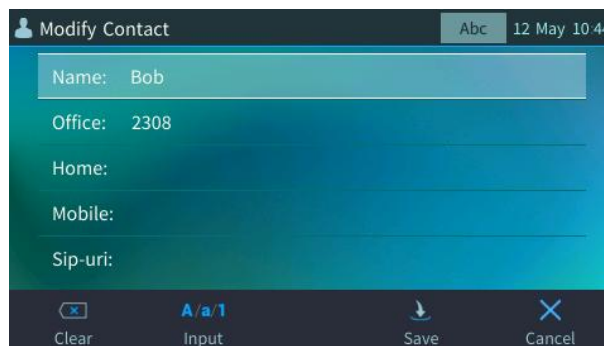

3. Edit the contact's details and press **Save**.

6.12.3 Deleting a Contact from the Personal Directory

Contacts can be deleted from the Personal directory. This can be necessary if they leave the company, for example.

To delete a contact:

1. Open the Personal directory (press the CONTACTS hard key on the phone), navigate to the name of the contact to delete and then press the **OK** hard key on the phone.



2. Press the **Delete** softkey; a 'Delete current contact?' warning message appears:

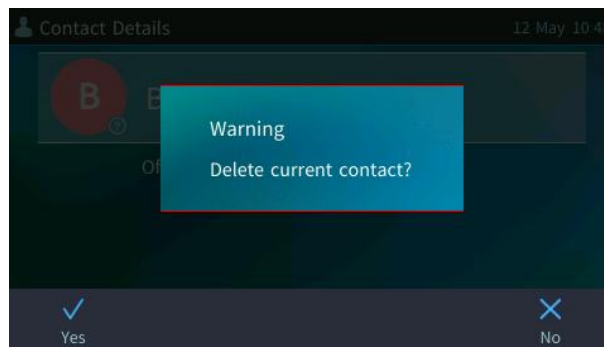

3. Press the **Yes** softkey to remove the contact from the phone directory or **No** if you want to keep the contact in the directory.

6.12.4 Searching for a Contact in the Personal Directory

The search feature enables you to quickly and easily locate a contact in a directory. The feature increases user productivity, especially if you have a long list of contacts.

To search for a contact in the Personal Directory:

Open the **Personal Directory**, and then do one of the following:

1. Navigate manually:

Scroll down through the list to locate the desired contact.

2. Search by name:

- Begin typing the first letter of the contact's name using the keypad. For example, to find *Jonathan*, press the **J** key. The directory will display all contacts beginning with **J**.
- Continue typing the next letters (e.g., **o**, **n**) to narrow the results further. The list will update to show contacts beginning with **Jo**, then **Jon**, etc.
- If there are no matching entries, the message **No Matches** will appear. To proceed:
 - ◆ Press **OK** to accept the result.
 - ◆ Press **Back** to exit the directory.
 - ◆ Press **Clear** to erase the input and start a new search.

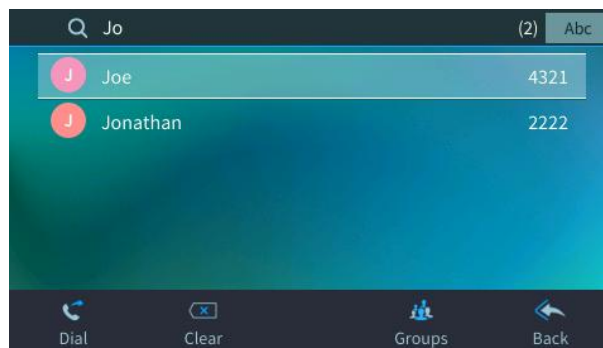

Select **A/a/1** input when for example you need to search for a contact in the Personal Directory. For more information, (see section 3.5 "[Inputting Data Using Multi-Tap](#)").

6.13 Programmable Softkeys (PSKs)

Located under your phone's LCD are four configurable softkeys. The idle screen by default displays (from left to right) **Contacts**, **Missed**, **DnD**, and **Forward** softkeys.



PSKs can only be configured by the network administrator (see the *Administrator's Manual*).

The four softkeys can be configured for different key events. The administrator can add additional softkeys. When additional softkeys (more than four) are added, the rightmost softkey is set to **More**. If you press it, you're scrolled to the next page of the softkey display.



You can scroll up to seven pages according to the supported number of configured softkeys (see the *Administrator's Manual*).

When a PSK is configured to connect to a voicemail server or to access an intercom, for example, you can be prompted after pressing the voicemail softkey to enter a personal voicemail code. After entering the voicemail code, you can press **Start** to dial to the voicemail server, **Clear** to clear the entry or **Cancel**.

6.13.1 Customized UI Experience



Only the network administrator can configure this feature. See the phone's *Administrator's Manual* for more information.

Users and / or enterprise management can ask their network manager to customize the **New Call** screen, **Ongoing call** screen and/or **Idle** screen.

Examples include:

- The softkey in the idle screen can be replaced with another softkey such as the **Received Calls** softkey.
- The ongoing call screen can be customized: The **BXfer** softkey for example can be replaced with the **New Call** softkey on the phones of users who infrequently transfer calls.
- The initiate call screen can also be customized: The **URL** dialing softkey, for example, can be replaced with the **Contacts** softkey.
- Administrators can customize the idle screen (shown in the figure below) in line with the preferences / requirements of enterprise management and / or the employees.
- For example, the **Contacts** softkey in the idle screen shown in the preceding figure can be replaced with the **Call** softkey

Figure 18: Example of Softkey configurations (to be change by Administrator)

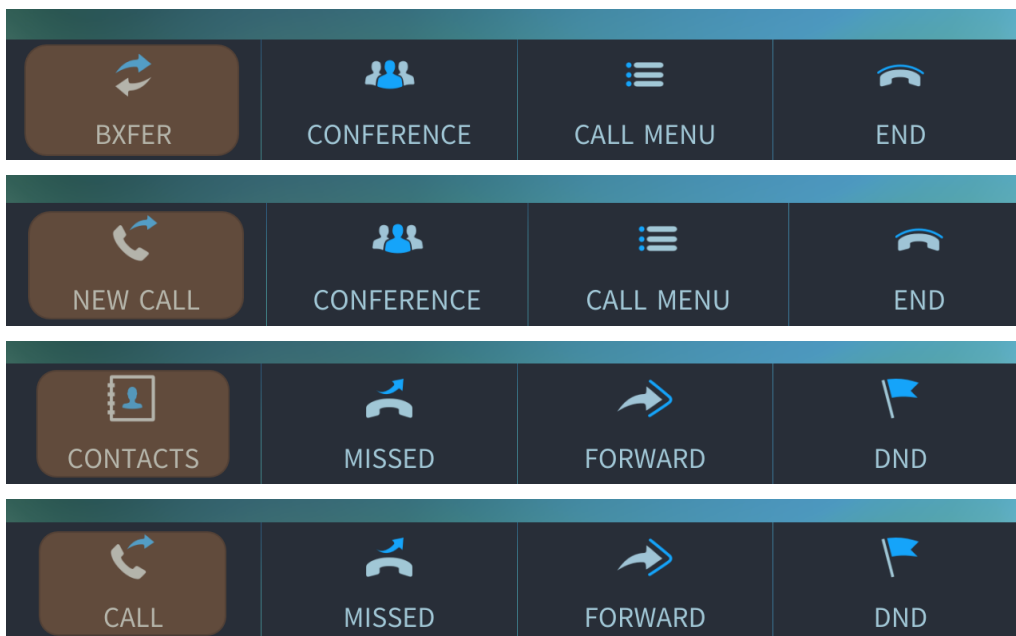

6.14 Configuring a Function/Programmable Key as a Speed Dial



Function Keys are available with expansion module.

Speed dials are private. They're for each user's own personal use. They're preserved even if you sign out, sign in as another user, sign out as that user, and then sign in again as your own user.

Any of the Function/Programmable Keys can be configured as a Speed Dial in the phone's idle screen. The instructions below apply for Function Keys, but the principle is identical to Programmable Keys.

To configure a Function/Programmable Key as a Speed Dial:

1. Press the **MENU** hard key, press the **Keys** item; that opens the Functional Key settings screen or long-press one of the 8 Programmable Keys (or 1-40 sidecar buttons).



2. Press < or > to navigate to and select **Speed Dial**.



3. Select **Call using** followed by < or > to determine which phone line this speed dial uses.
4. Enter the number of the contact or select the contact from a directory.
5. Enter a Key Label – the name of the contact to be displayed on the sidecar.
6. Press the displayed **Save** softkey.

6.14.1 Configuring a Programmable Key for Speed Dialing via Calling Line of Choice

You can configure a Programmable Key for speed dialing to be initiated by a speed dial calling line of your choice. The feature only applies to a conference phone configured with multiple lines.

The feature determines through which line the call goes out when speed dialing. For example: A phone is configured with two lines, 0002 and 0003. When configuring a speed dial, 0002 or 0003 can be configured as the default line through which to (speed) dial out. For example, one line may be for internal calls, the other for external calls.

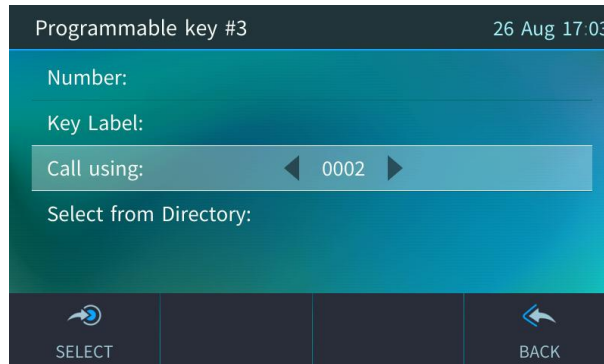

6.14.2 Configuring Pause Dialing for a Speed Dial to an Ext. behind an IVR

Your network administrator can configure pause dialing for a Speed Dial, in order to create a time break. This is typically required for a Speed Dial which dials a destination extension number that is behind an Interactive Voice Response (IVR) system.



Consult your network administrator if you need a pause dialing configured for a Speed Dial. See the *Administrator's Manual* for more information.

6.14.3 Configuring a Speed Dial Key through the Personal Directory

You can configure a Speed Dial key through the Personal Directory.

To configure a Speed Dial key through the Personal directory:

1. Open the 'Personal directory' (**MENU** key > **Contacts** > **Personal directory**), select the contact and then press the **Edit** softkey.
2. Navigate to the phone number for which to define a speed dial and press the **Sp. Dial** softkey.
3. Navigate to an 'Empty' or to a previously defined speed dial number. In the latter case, the previously defined speed dial number will be overwritten.
4. Press the **Select** softkey and then navigate to and select an 'Empty' Function/Programmable Key.
5. Press the **Save** softkey; the Speed Dial is assigned to the contact and displayed in the sidcar.

6.14.4 Configuring a Speed Dial Key in the Sidecar Fields

You can configure up to 8 Speed Dials in the sidecar fields.

To configure a Speed Dial key in a sidecar field:

1. On the sidecar, long-press a button adjacent to a field.
2. In the Function/Programmable Key screen that opens, select **Speed Dial**.
3. In the 'Function/Programmable Key #n' screen that opens, configure the phone number of the contact to whom to assign the Speed Dial key.
4. Enter a label that will facilitate quick and easy identification of the key.
5. Press the **Save** softkey; the field displays the name of the contact to whom you assigned the Speed Dial.

6.14.5 Editing a Speed Dial

Editing a speed dial will usually be necessary if a contact's phone number changes.

To edit a speed dial:

1. Long-press the speed dial Function/Programmable Key, and then press the  button.

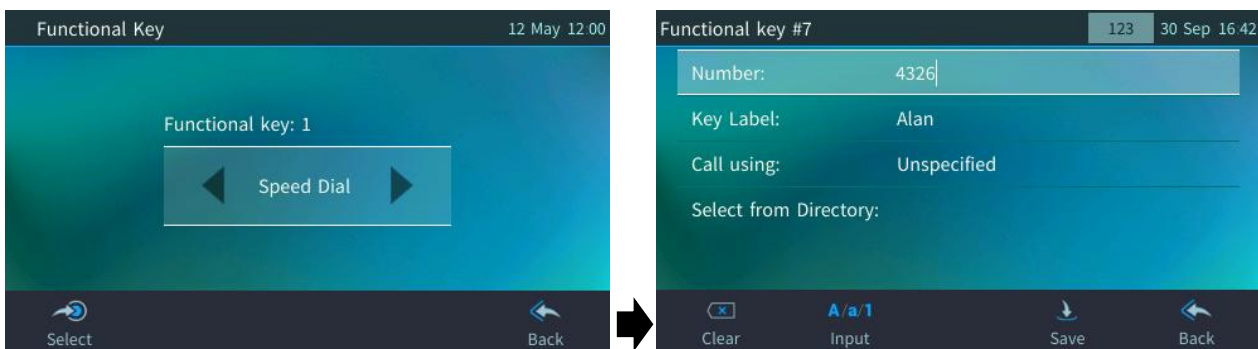

2. In the 'Number' field of the Function/Programmable Key screen, press the **Clear** softkey to delete digits.
3. Navigate to the 'Key Label' field and edit by pressing the **Clear** softkey to delete letters.
4. Save the edit.

6.14.6 Deleting a Speed Dial

To delete a Speed Dial:

1. Long-press the speed dial Function/Programmable Key, and then press the  button.
2. Navigate to 'Empty' and then press the **Select** softkey.

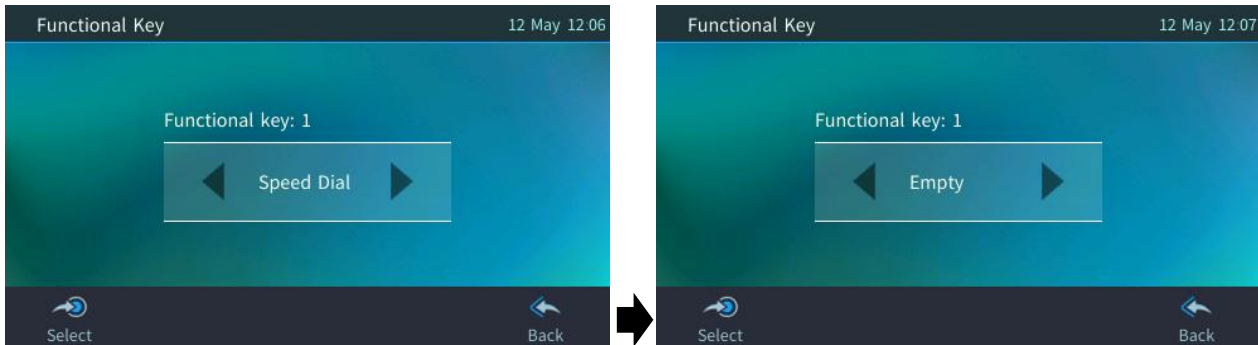

3. The idle screen appears, and the Speed Dial is removed.

6.15 Configuring a Function/Programmable Key for Direct Voice Dialing

Any of the eight Programmable Keys can be configured as a Key Event. A Key Event can be Dialed Calls, Missed Calls, Received Calls, Directory, DnD All, and Forward. The figure below, for example, shows a programmable key configured as a 'Dialed' Key Event. Pressing the adjacent programmable key directly opens the Dialed Calls screen.

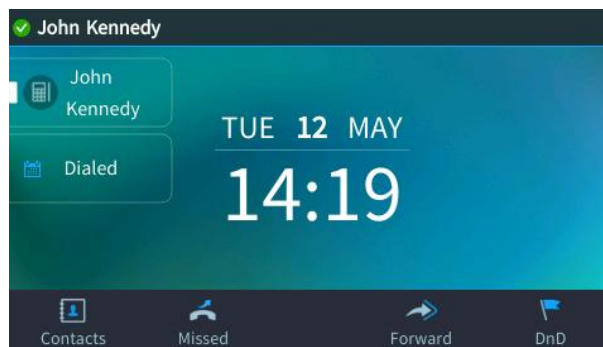

Functional Keys are available with the expansion module.

Other Key Events you can configure:

- Missed Calls
- Received Calls
- Dialed Calls
- Contacts
- DnD All
- Forward All
- Notifications

The section below shows how to configure a Programmable Key as a Key Event.

To configure a programmable key as a Key Event:

1. Long-press any of the eight Programmable Keys of the phone screen or press the **Menu** softkey and select the **Keys** item.

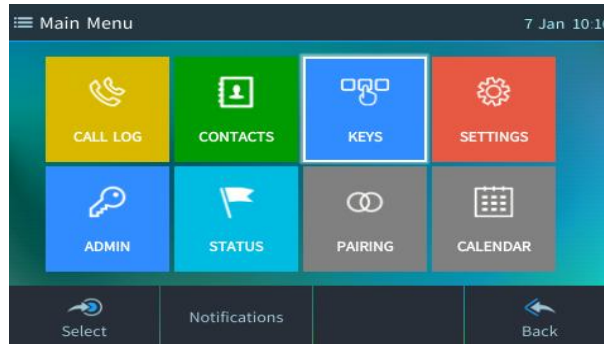

2. Select **Programmable Keys** and then select an 'Empty' Programmable Key.



3. Use the Navigation key to navigate to and select **Key Event**:

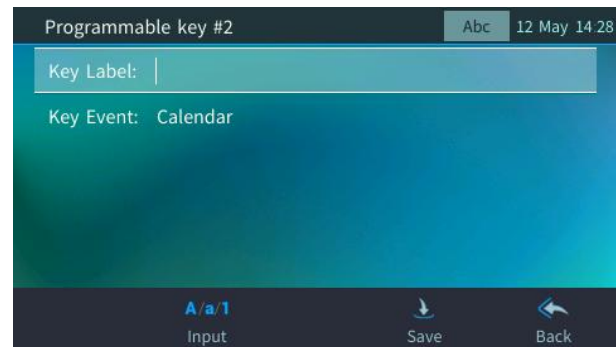
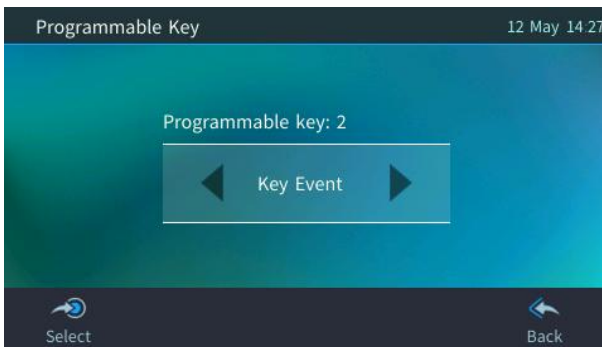

4. In the 'Key Label' field, configure an identifier that you'll easily identify in the phone screen, e.g., 'Dialed'.
5. In the 'Key Event' field, select the Key Event you want to configure, for example, 'Dialed Calls'.

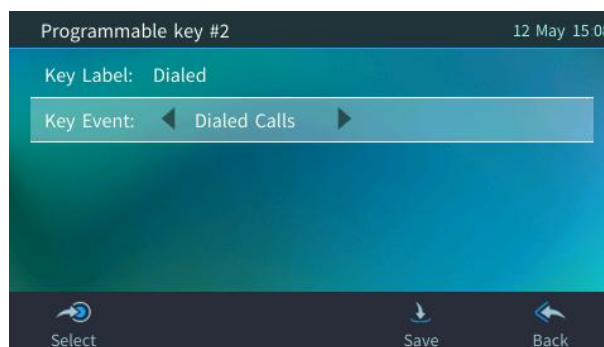

6. Save the configuration and view in the phone's idle screen the Key Event you configured.

6.16 Configuring a Function/Programmable Key for Paging



Functional Keys are available with the expansion module.

Any of the Function/Programmable Keys can be configured to page a group. The feature allows live announcements to be made (paged) from a phone to a group of phones, to notify a team (for example) that a meeting is about to commence. The paged announcement is multicast via a designated group IP address, in real time, on all idle phones in the group, without requiring listeners to pick up their receivers. Listeners view the name of the group displayed on phone screens when the paging call comes in.



The feature must be enabled by the network administrator before a Function/Programmable Key can be configured for paging. See the *Administrator's Manual* for more information.

To configure a Function/Programmable Key as a paging dial:

1. In the phone's idle screen, press the ... button.



Alternatively, you can press the **MENU** hard key, press the **Keys** item; that opens the Function/Programmable Key settings screen.

2. Press < or > to navigate to and select **Paging** and then press the **Select** softkey; the Function/Programmable Key #n' screen opens.

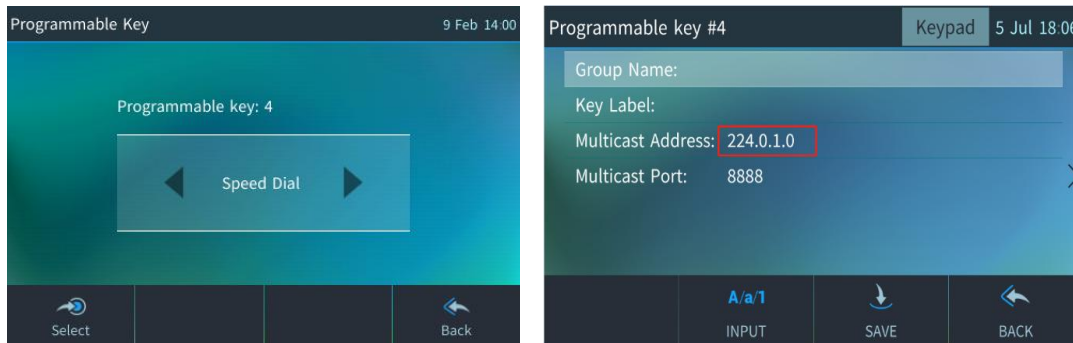

3. In the 'Group Name' field, enter the name of the group, to be displayed in the phone's screen when there's an incoming/outgoing paging call.
4. In the 'Key Label' field, enter the name of the key to be displayed in the idle screen that you will press to make a paging call.
5. In the 'Multicast Address' field, enter the paging group's multicast IP address. Default: 224.0.1.0. For phones to be in a group, all must be configured with the identical multicast address.
6. In the 'Multicast Port' field, enter the group's port. Default: 8888. For phones to be in a group, all must be configured with the same port.
7. Press the **Save** softkey; a key is defined in the idle screen as a paging dial.

6.17 Deleting a Function/Programmable Key

A Function/Programmable Key can be deleted after you configure it if you no longer find it useful (for example).

To delete a key event:

1. In the phone's idle screen, long press the Function/Programmable Key.

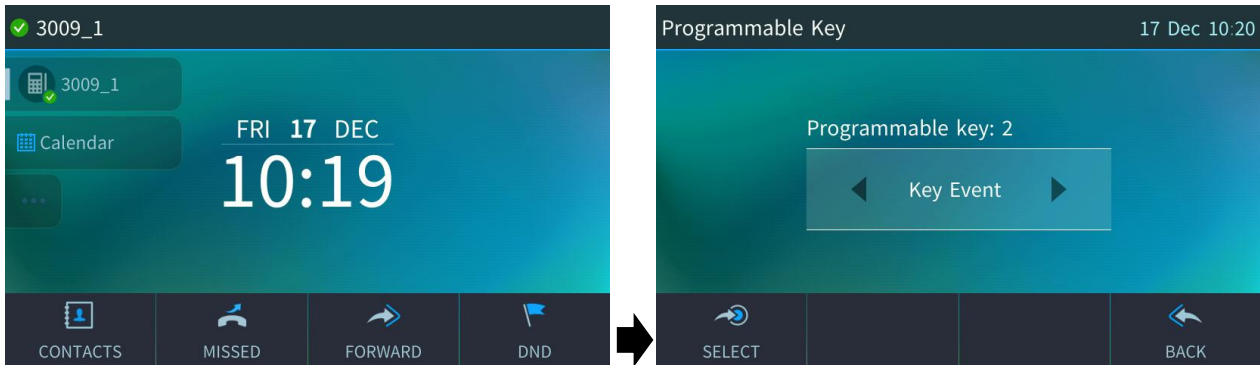

2. In the Function/Programmable Key screen that opens, navigate to and select **Empty**; the Function/Programmable Key is removed from the idle screen.

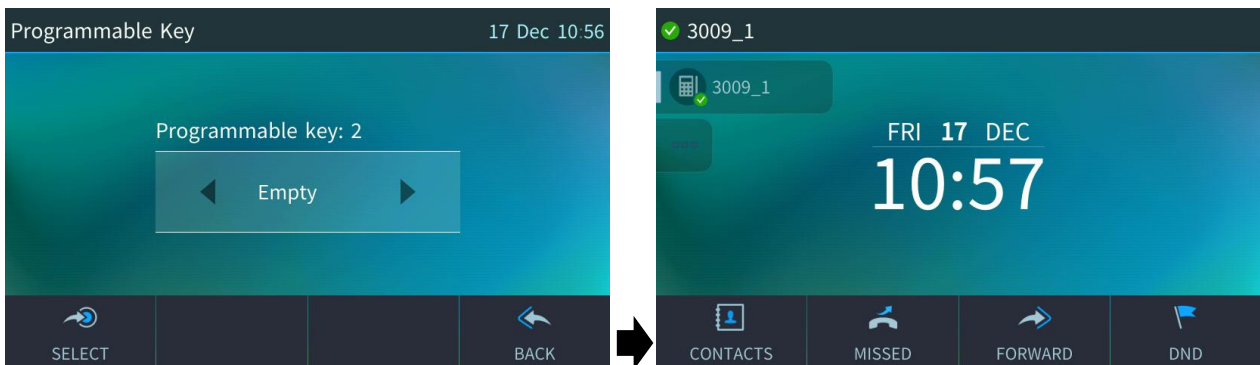

7 Performing Advanced Operations

This section describes how to perform advanced operations.

7.1 Answering Waiting Calls

You can accept a call on an extension on which there already is an active call.

To answer a waiting call:

1. A call with Jack Brown is in progress:

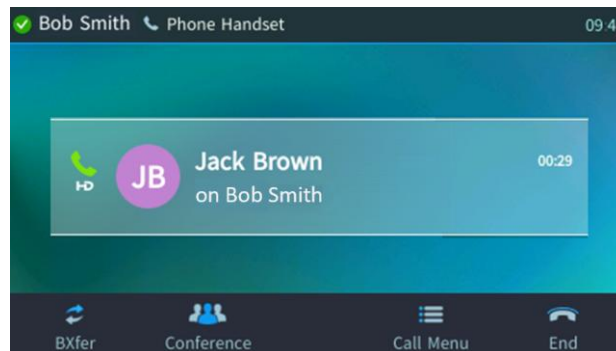

2. A call comes in from Adel Vance:



To answer Adel Vance:

1. Press the **Accept** softkey; the waiting call from Adel Vance is answered; the previous call from Jack Brown is put on hold:

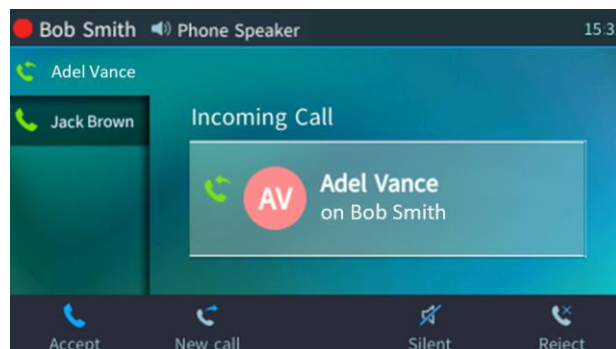

2. To toggle between calls, press the navigation control's upper or lower rim, or press the caller's name in the screen.:



To enable / disable the call waiting feature, see section 6.5 "Enabling Call Waiting".

7.2 Placing Calls On Hold

You can place a call on hold in order to answer an incoming call (see Section 7.1) or to make another call. The party put on hold will hear music played (Music on Hold (MOH)).

To place a call on hold:

1. Accept an incoming call.
2. Press the **HOLD** hard key; the call is put on hold.

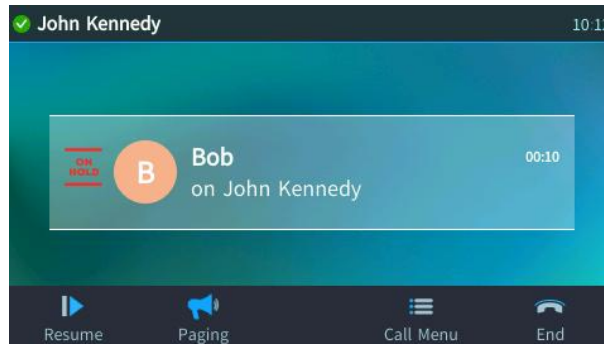

To retrieve a call on hold:

- Press the **HOLD** key again or press the **Resume** softkey.



When using the handset in a call, if the handset is on-hooked after putting the call on hold, the call is *not* disconnected and the *audio is switched to the speaker*. For the call to be *disconnected*, as it was in earlier versions, refer to your network administrator.

7.3 Calling a Contact Listed in the Directory

You can call a contact listed in your directory.

To call a contact listed in the directory:

1. Press the **CONTACTS** key and then select the directory.

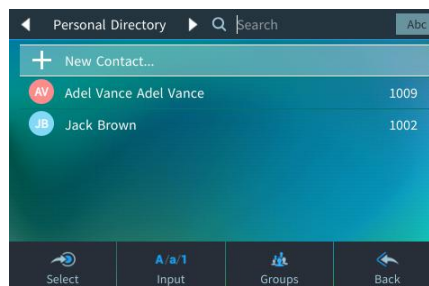

2. Navigate to the contact to call.
3. Press the **Dial** softkey or the **OK** key.

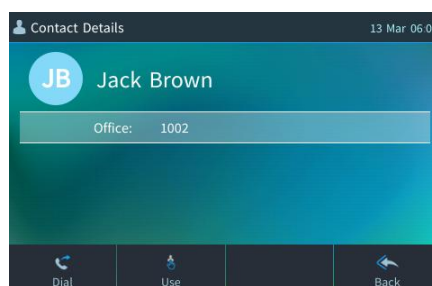

7.4 Accessing Office 365 Exchange Services in Generic SIP Mode



For Office 365 to be available to users, the network administrator must enable it. See the Administrator's Manual for details.

To sign-in to Office 365 exchange services via cloud:

1. From the **Accounts** section, click the **Add** button to start the sign-in process.



2. In the sign-in options, choose **Web Sign-in (Cloud)**.

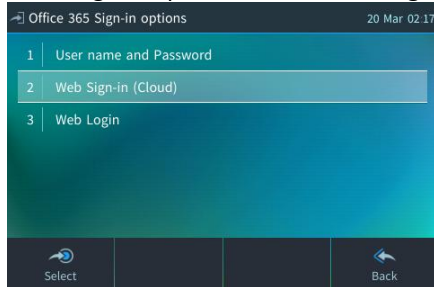

3. A pairing code and sign-in URL is displayed.

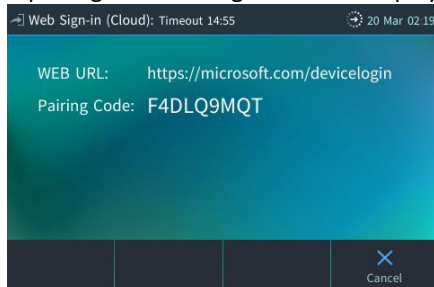

4. Open the URL in your browser and enter the **pairing code** shown on the screen.



5. Log in with your Office 365 credentials in the browser window that opens.

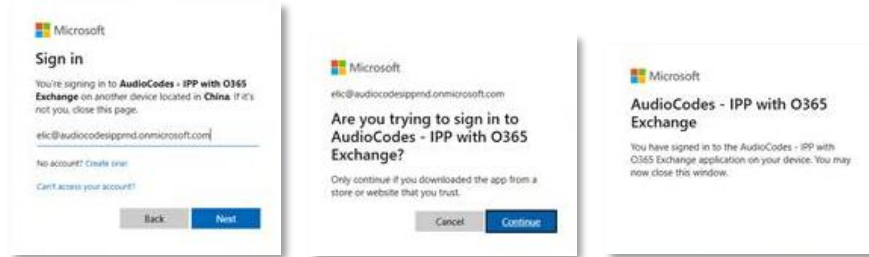

6. Once sign-in is complete in the browser, the UI will show "Signing In..."

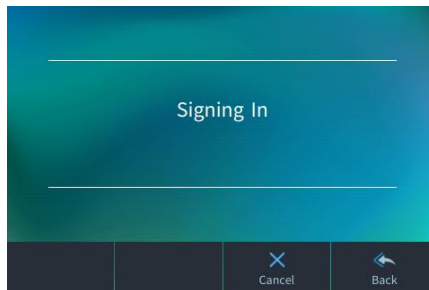

7. Select **Menu > Settings > Accounts** to confirm that your Office 365 account is now signed in.

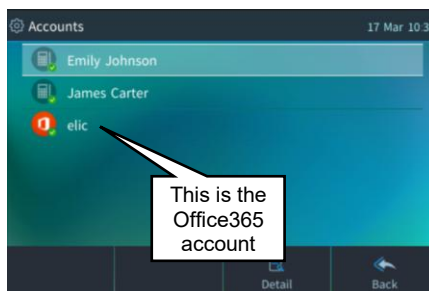

7.5 Using Office365

To view calendar :

- Press **Menu > Calendar** to view calendar

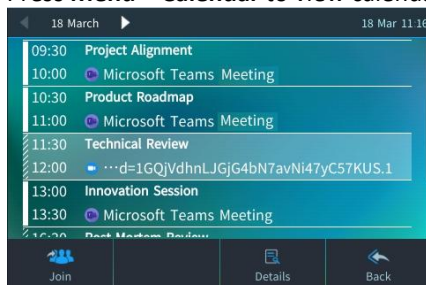

- Join Teams/Zoom meeting via calendar

To search contact from corporate directory:

- Search contact from corporate directory

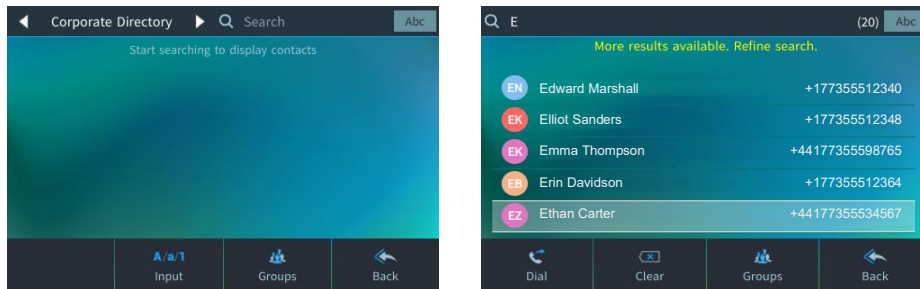

7.6 Handling Multiple Incoming Calls

The phone is capable of handling up to eight concurrent calls per line. Multiple calls can be put on hold, and you can switch between them. This feature is valuable for front desk personnel.

To manage multiple incoming calls:

- If a call comes in from Adel Vance followed by a call from Jack Brown, then when you answer Jack Brown, Adel Vance is put on hold.
- If a third call from Hilary Gammond comes in, and you answer it, Jack Brown is also put on hold, so now both Adel Vance (caller 1) and Jack Brown (caller 2) are on hold.

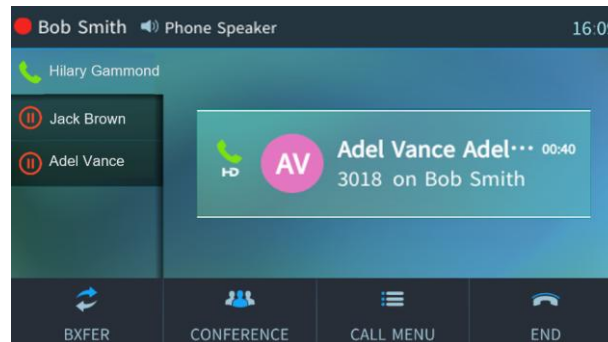

To toggle between callers:

- Press the navigation control button's upper or lower rim to navigate from one caller to another, or
- Press the caller's name in the screen.

7.7 Using a Speed Dial to Call a Contact

To quickly place a call you can press the Function/Programmable Key that you configured for speed dialing.

To configure a Function/Programmable Key for speed dialing, see [Section 6.14 Function/Programmable Key as a Speed Dial](#).

To speed dial:

- Press a Function Key that you configured for speed dialing.
- OR-
- Press a Programmable Key that you configured for speed dialing.



Long-pressing a Function/Programmable Key that is not configured for speed dialing allows you to configure one. See [Section 6.14 Function/Programmable Key as a Speed Dial](#).

7.8 Accessing Speed Dials when in a Call

You can access your speed dials when in a call to (for example):

- transfer the call to a third-party
- add a participant to a conference

To access your speed dials when in a call:

1. When in a call, press the **BXfer** softkey (for example); the 'Blind transfer to...' screen opens displaying the **Contacts** softkey.



2. Press the **Contacts** softkey to access your speed dials.

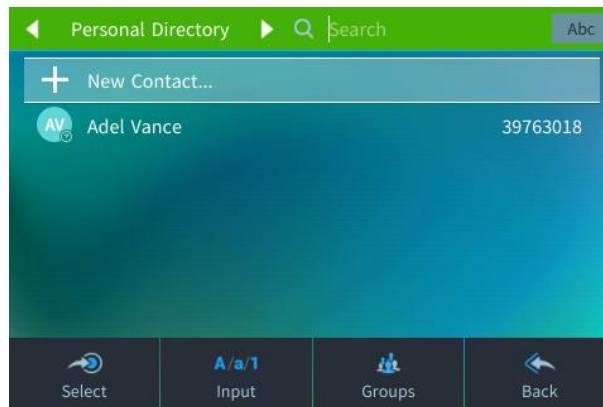

3. In the Speed Dial screen that opens, select the Speed Dial of the contact to transfer the call to.

7.9 Transferring Calls

You can transfer a call to another party using blind transfer (default) or consultative transfer.

Transfer Method	Description
Blind	Connects another party to a third-party <i>before</i> the third-party answers.
Consultative	Connects another party to a third-party <i>after</i> the third-party answers and agrees to take the call from the second party.



The hard TRANSFER key on the phone *by default* performs a *blind transfer*. Your network administrator can change the key's default functionality to *consultative transfer* (see the *Administrator's Manual* for more information).

7.9.1 Performing a Blind Transfer

A second party can be transferred to a third-party before the third-party answers, without consulting with them.

To perform a blind transfer:

John Jones asks you (Bob Smith) to transfer him to Allen Gray.

1. Press the **TRANSFER** key on the phone or press the **Call Menu** softkey > **Blind transfer**. John Jones is put on hold.

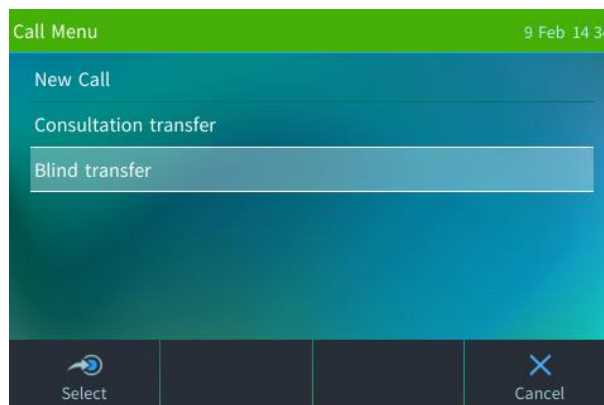

2. Enter Allen Gray's number (3018) and then select **Transfer**.

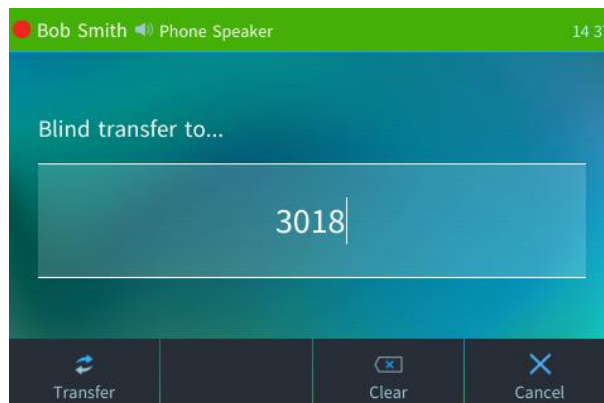

- Allen Gray's phone (3018) rings. Your call with John Jones ends immediately, and he is transferred to Allen Gray.

Performing a Consultative Transfer You can consult with a third party before transferring a second party to the third party. This consultation (semi-attended) transfer can be performed using the **Trans.** softkey or the TRANSFER key on the phone.



The **Trans.** softkey is not available by default on the phone and must be configured in the configuration file. For more information, see the *Administrator's Manual*.

To perform a consultation transfer:

While on a call with Jack Brown, he asks you (Bob Smith) to transfer him to Allen Gray.

- Press the **Call Menu** softkey and select **Consultation transfer**.

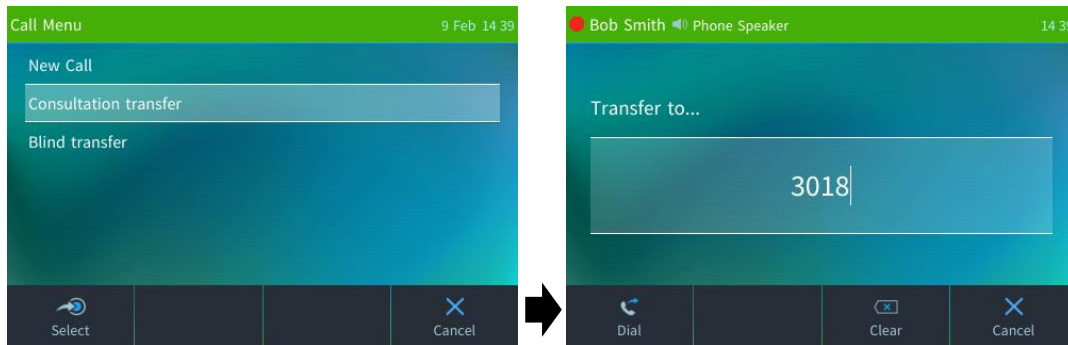

- Enter Allen Gray's number (3018)
- Press the **Dial** softkey. Allen Gray's phone rings and he answers.

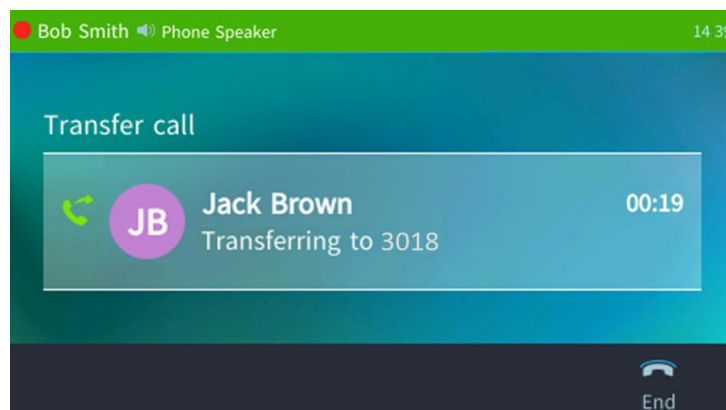

- Speak with Allen Gray to confirm if he is willing to take the call.
- If he agrees, press the **Transfer** softkey or press the **TRANSFER** hard key. Jack Brown is then connected to Allen Gray, and your call ends.

7.9.2 Transferring a Call to a Remote Party on Hold

This feature allows you to transfer a call to another person with whom a call has been established, by selecting the call from a list of calls. You can consult with any person with whom a call has been established, without needing to use the Consultation Transfer procedure.

To activate the feature:

1. Press the **BXfer** softkey and then press the **Menu** softkey and select **Calls**.

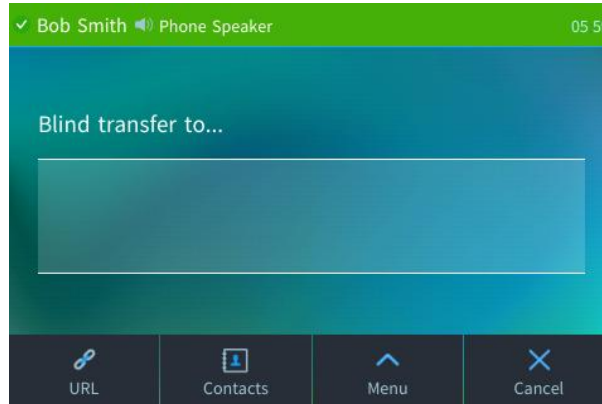

2. Select the active call; the call is then transferred to the remote party with whom that call was established.

7.9.3 Merging Calls

During a call, you can add another participant and merge them into a conference call. Merging works similarly to adding a participant to a conference and can be done using the phone's softkey."



A regular call cannot be merged with an active conference call.

To merge calls:

While on a call with Jack Brown, you (Bob Smith) decide to add Adel Vance.

1. Press the **Call Menu** softkey, select **New Call**, enter Adel Vance's number (3018), and press the **Dial** softkey.
2. Jack Brown is placed on hold while you call Adel Vance.
3. When Adel Vance answers, press the **Call Menu** softkey. The Call Menu screen appears.

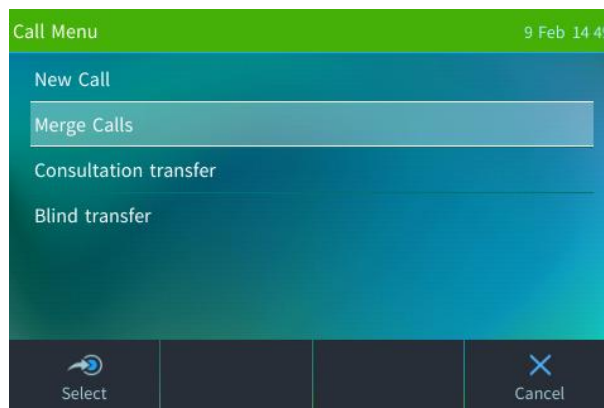

4. Select **Merge Calls** to combine your calls with Jack Brown and Adel Vance.
5. All three participants are now in a conference call.

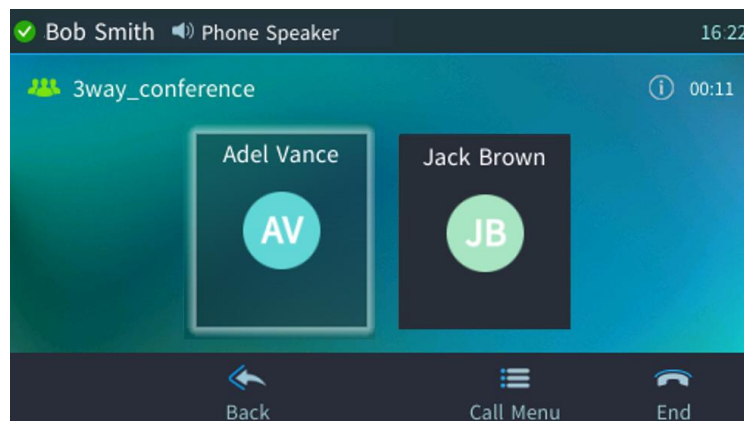

7.9.4 Leaving a 3-Way Conference You Set up without Disconnecting the Others

A caller who sets up a three-way conference call with two other parties can leave it without disconnecting the two other parties. The two others continue uninterrupted. The 'Drop from Conference' feature supports this capability.

To leave a conference you set up, without disconnecting the other parties:

- On-hook to end the call or press the **End** softkey; you're disconnected from the conference; the two remaining parties continue unaffected.



The initiator of a call conference can also drop out of the conference by on-hooking the phone, without disrupting parties B and C. In a conference call initiated by user A with participants B and C, user A can on-hook to drop out, and B and C can continue talking uninterrupted. Previously, only a softkey option was available for dropping out. A new enable parameter commands the new SIP behavior (a 'Refer' is sent when user A on-hooks).

7.10 Activating Do Not Disturb

The Do Not Disturb (DnD) feature stops the phone from ringing if anyone calls. If DnD is activated and someone calls:

- The caller hears a tone indicating that your phone is busy.
- The call is blocked and the idle screen indicates 'Missed Calls'.

To activate DnD:

1. Make sure your phone is in idle state and that the idle screen is displayed, i.e., that you're not in an active call or dialing a number.
2. Press the **DnD** softkey:

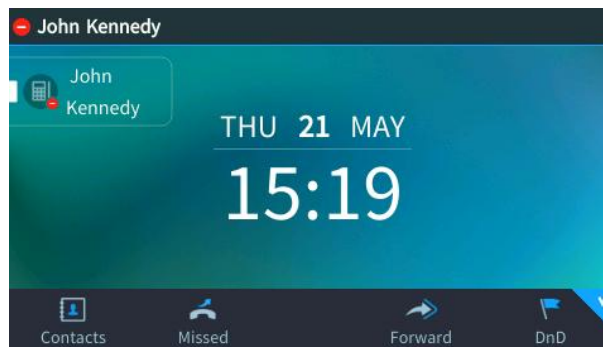

The screen displays a red 'no entry' icon adjacent to the extension line indicating that incoming calls are blocked, as well as a tick symbol next to the **DnD** softkey, as shown in the figure above.



- If DnD is activated on all line extensions, the tick symbol is colored *light blue*.
- If DnD is activated on only some of the line extensions, the tick symbol is colored *gray*.

To activate DnD on multiple line extensions:

1. Make sure your phone is in idle state and that the idle screen is displayed, i.e., that you're not in an active call or dialing a number.
2. Press the **DnD** softkey:



3. Select All Extensions to activate the feature on all line extensions or navigate to and select the extensions on which to activate DnD and then **Save**.

To deactivate DnD:

1. Make sure that the phone is in idle state and that the idle screen is displayed, i.e., that you're not in a call or dialing a number.
2. Press the **DnD** softkey; the 'no entry' icon is no longer displayed on the screen and your phone will now ring for incoming calls.



If your enterprise deployed a BroadSoft server, your network administrator can control the DnD on the phone from the BroadSoft server.

7.11 Retrieving Voice Mail Messages

Voice mail is indicated *per line* in the phone's idle screen when the phone is in a multi-line configuration. You can determine if new messages are in your Voice Mail if the Voice Mail key is lit red.

To listen to Voice Mail messages:

1. Press the Voice Mail key on the phone (it'll be illuminated red if there's voicemail); you're prompted to enter the Voice Mail number.

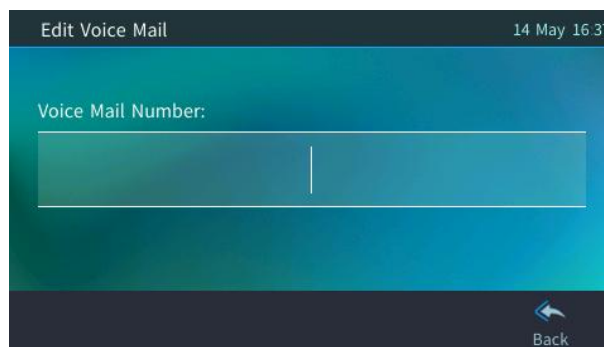

The preceding screen will only be displayed if your network administrator did not configure the Voice Mail server number.

2. Enter the Voice Mail number (get it from your network administrator) and press the **Save** softkey.
3. Press the Voice Mail key again; the phone dials your enterprise's Voice Mail box; the phone establishes the call with the server.
4. Enter DTMF to pass server authentication and then listen to your voice mail.

7.12 Parking a Call

A call can be transferred to a "parking lot" where it can be picked up on any other phone in the enterprise by a party who dials a retrieval number to retrieve it. The retrieval number is configured in the server's parking lot parameter by the network administrator.



Don't park a call unless you know precisely who you want to answer it. If you park a call, it can be answered by anyone in the enterprise listed in the server's parking lot parameter.

To configure a Programmable Key for parking a call:

1. Long-press any of the unconfigured buttons adjacent to the sidecar fields.
2. Press the right rim of the navigation key button to navigate to and select **Parking Lot**.

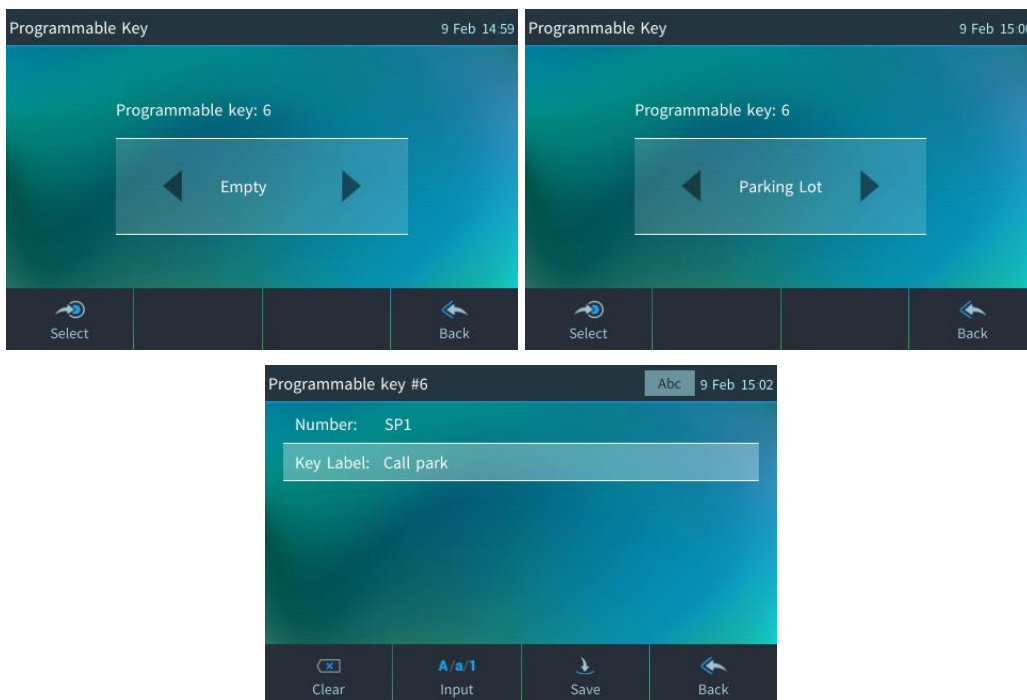

3. Obtain the 'Number' from your network administrator and enter it in the 'Number' field.
4. Enter an intuitive 'Key Label' for enhanced usability, for example, **Call park**, and press **Save**.

To use the feature:

- When you are in a call, press the configured button adjacent to the sidecar field. Go to the other phone on which you want to pick up the parked call. Pick it up on that phone.

7.13 Configuring Group Call Pickup (GCP)

GCP capability lets an employee take a call coming in on a colleague's phone, on their phone. If an employee in an open space hears a colleague's phone ringing and knows that colleague is unavailable, instead of having the call go unanswered and routed to voicemail, the call can be redirected and answered by the available employee. Only employees configured in the SIP server's GCP parameter can pick up the call. Consult your network administrator if required.

7.14 BLF Call Pickup

This feature allows you to 'pick up' on your phone a call that comes in on another employee's phone but that employee is OOO (for example).

After configuring a speed dial for an employee, when a call comes in on that employee's phone the sidecar's BLF button next to the speed dial *on your phone* flashes green, allowing you to 'pick up' the call by pressing the BLF button.



Before using this feature, make sure your network administrator has enabled it on the server.

7.15 Managing a Conference

Users can manage a three-way (or more, based on configuration) conference call from the phone. This conference capability is phone-based, allowing the phone call initiator to add participants.

To start a conference:

1. In the phone's idle screen, make a call and press **Conference**.



2. In the Add Participant screen that opens, enter the participant's phone number and press the now activated **Dial** softkey.

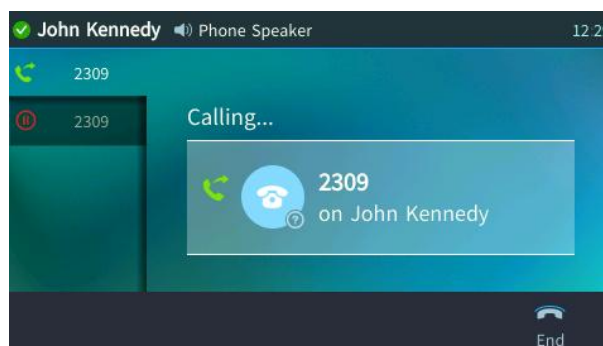

3. When the call is established, the conference has already started.

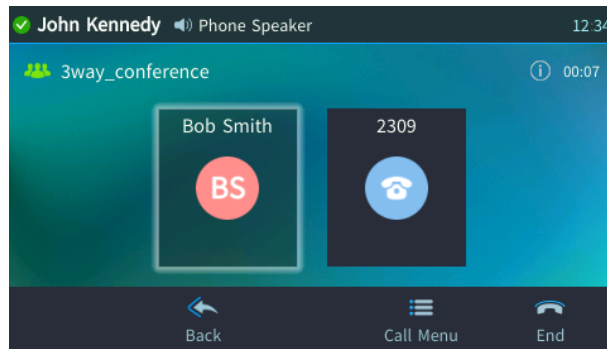

To view conference information:

- In the Conference screen, press the Call Menu softkey and then select **Conference Info**.

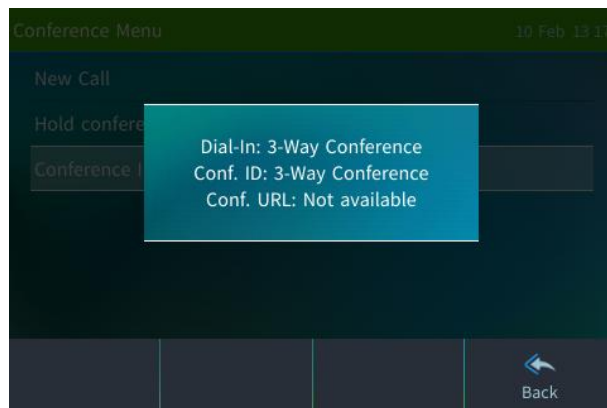

7.16 Muting the Microphone

During a call, you can mute the microphone of the handset, headset, or speaker so that the other party cannot hear you. While the call is muted you can still hear the other party. Muting calls can also be used during conference calls.

To mute/unmute:

1. During a call, press the mute key on the phone 
2. To unmute, press the mute key again and resume the conversation.

7.17 Screens Switcher

Screen switcher lists all open screens and allows switching to one of them. Windows selection screen is initiated by a long press in the Menu Hard Key or Soft Key. It can also be initiated by pressing “X” Hard Key on Idle screen.

Figure 19: Screen Navigation Switcher

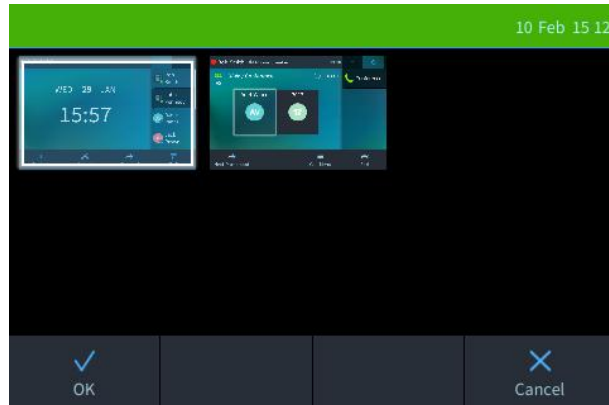

7.18 Configuring Bluetooth on the Phone

The phones support integrated Bluetooth for (wireless) USB headset connectivity.



- Beta level
- Only applies to the **C450HD-BW** model.
- Supported in specific regions such as the USA, Canada, the European Union, Switzerland, South Africa and Israel, and requires a specific CPN with a 'BW' suffix when ordering. For an updated list of supported regions, contact AudioCodes.

To enable Bluetooth on the phone:

1. Access the Bluetooth screen (**Menu > Settings**):

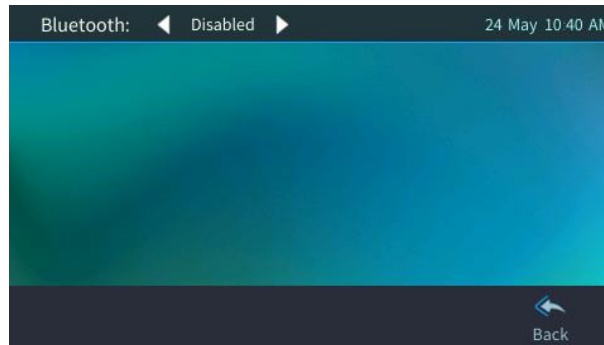

2. Press the right/left rim of the navigator key to configure **Enabled**:

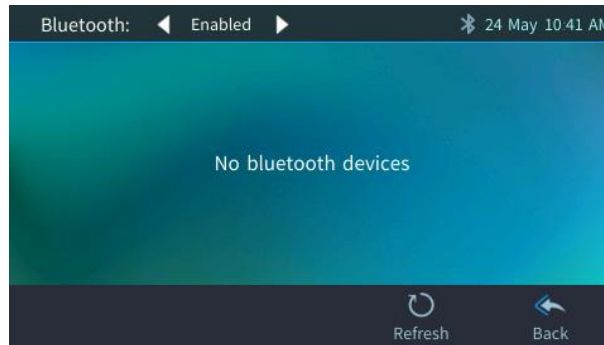

3. Configure the device (Bluetooth headset or speaker) to allow pairing and then press the **Refresh** softkey; the phone attempts to discover available devices:

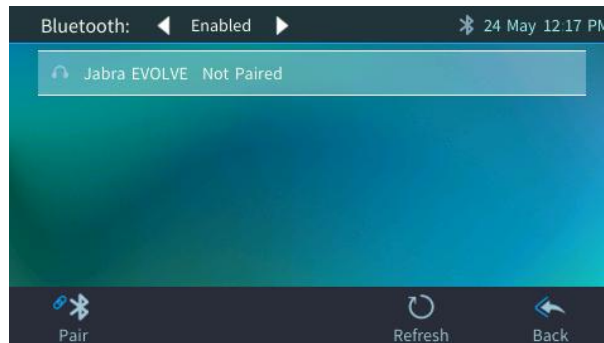

4. Press the **Pair** softkey to pair the device. After pairing is complete, the phone displays 'Connected'.

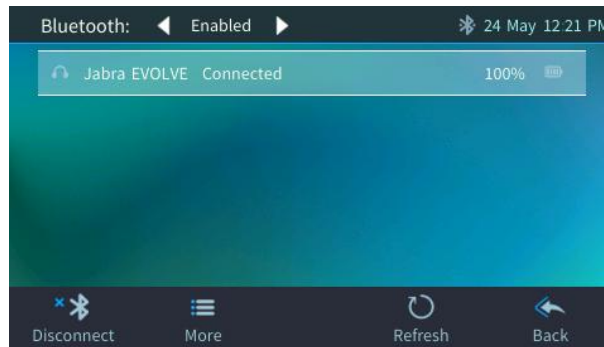

When the phone is connected via Bluetooth, its battery level is visually indicated adjacent to the 'Connected' indication. Bluetooth connectivity is indicated on the upper bar by the Bluetooth icon.

 indicates Bluetooth is enabled, not paired.

 indicates that the device is connected.

5. Start using the device.

- The following Bluetooth call controls are supported (and can be used from the Bluetooth device itself):
 - ◆ Accept call
 - ◆ End call
 - ◆ Reject call
 - ◆ Mute/unmute
 - ◆ Volume up/down



- All Bluetooth headsets are defined by the phone as headsets and the phone's headset hard key onhooks / offhooks the headset.
- Connecting both the USB headset and the Bluetooth headset is currently not recommended.
- Known speakers such as the HRS 457, Jabra 710 and Jabra 510 are not defined as Bluetooth headsets. Users can define a known Bluetooth speaker as the phone's default Audio Device from **Settings > Audio Device**:

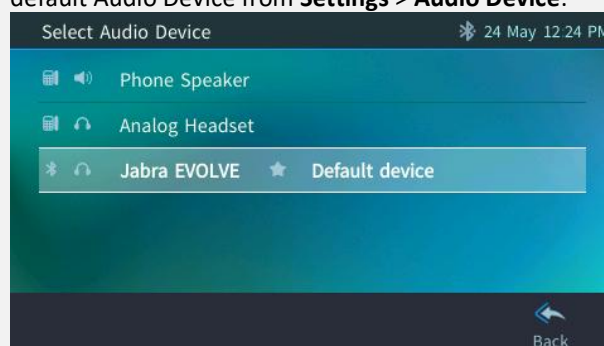

- After it is selected, the Bluetooth speaker will be used whenever a call is answered via the **Accept** softkey or initiated via the **Dial** key. The phone's hard speaker and headset keys are used for its speaker and connected headset, for example, USB headset.

8 Troubleshooting and Support

Read this section if a problem with a phone occurs. Contact your administrator if necessary.

Table 7: Troubleshooting

Symptom	Problem	Corrective Procedure
Phone is off (no screen displays and LEDs)	Phone is not receiving power	<ul style="list-style-type: none"> Verify that the AC/DC power adapter is attached firmly to the DC input on the rear of the phone. Verify that the AC/DC power adapter is plugged into the electrical outlet. Verify that the electrical outlet is functional. If using Power over Ethernet (PoE), contact your network administrator to check that the switch is powering the phone.
'LAN Link Failure' message displayed in the screen	No LAN connection	<ul style="list-style-type: none"> Verify that the LAN cable is connected securely to the LAN port on the rear of the phone. Verify that the other end of the LAN cable is connected to the network (switch). If it's not, inform your network administrator.
Phone is not ringing	Ring volume is set too low	<ul style="list-style-type: none"> Increase the volume (see Section 5.13.1)
Screen display is poor	Screen settings	<ul style="list-style-type: none"> Adjust the phone's screen brightness (see Section 5.8)
Headset has no audio	Headset not connected properly	<ul style="list-style-type: none"> Verify that your headset is securely plugged into the headset port located on the side of the phone. Verify that the headset volume level is adjusted adequately (see Section 5.13.5).

8.1 Monitor the Status of Software Modules

Administrators can monitor the status of the device's various software modules. For example, if initial provisioning fails, or if a network or Device Manager connectivity issue occurs, the system provides clear indications of the root cause.

Debugging is available directly from the phone screen without relying on external systems. Administrators can verify connectivity independently of external applications by navigating to **Status > System State**.

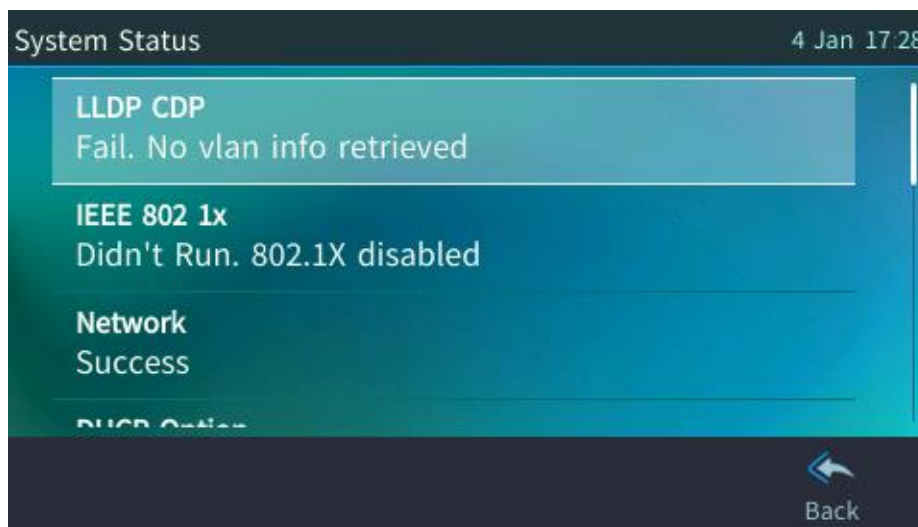

8.2 Manually Reboot IP Phone

In some cases, a manual reboot of the phone is required. The reboot option can be found in the Settings menu.

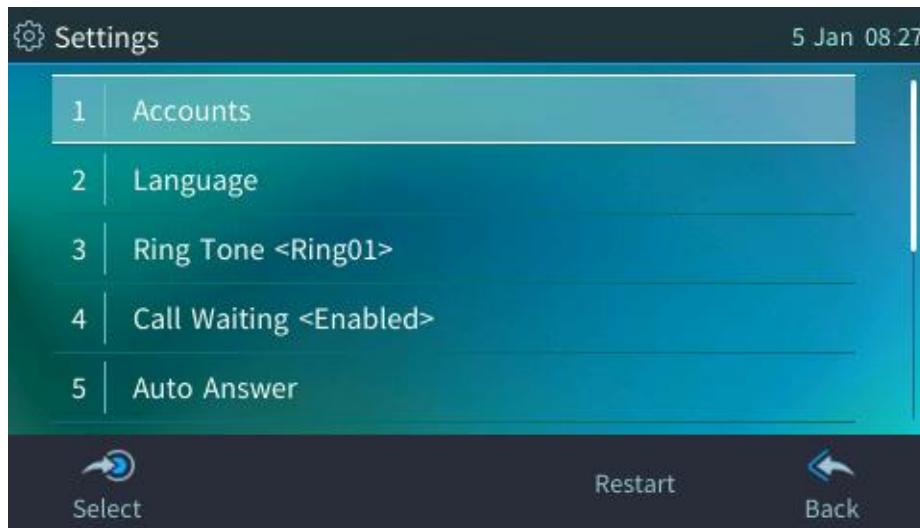

International Headquarters

Naimi Park
6 Ofra Haza Street
Or Yehuda, 6032303, Israel
Tel: +972-3-976-4000
Fax: +972-3-976-4040

AudioCodes Inc.

80 Kingsbridge Rd
Piscataway, NJ 08854, USA
Tel: +1-732-469-0880
Fax: +1-732-469-2298

Contact us: <https://www.audiocodes.com/corporate/offices-worldwide>

Website: <https://www.audiocodes.com>

©2026 AudioCodes Ltd. All rights reserved. AudioCodes, AC, HD VoIP, HD VoIP Sounds Better, IPmedia, Mediant, MediaPack, What’s Inside Matters, OSN, SmartTAP, User Management Pack, VMAS, VoIPerfect, VoIPerfectHD, Your Gateway To VoIP, 3GX, AudioCodes One Voice, AudioCodes Meeting Insights, and AudioCodes Room Experience are trademarks or registered trademarks of AudioCodes Limited. All other products or trademarks are property of their respective owners. Product specifications are subject to change without notice.

C450HD IP Phone User’s Manual (3.5.4) - Generic SIP Document #: (Ver02-12Jan26)

